



The Town of Hilton Head Island
Board of Zoning Appeals Regular Meeting
Monday, May 20, 2019 – 2:30 p.m.
Benjamin M. Racusin Council Chambers
AGENDA

*As a courtesy to others please turn off / silence ALL mobile devices during the meeting.
Thank You.*

1. **Call to Order**
2. **Pledge of Allegiance**
3. **FOIA Compliance** – Public notification of this meeting has been published, posted, and distributed in compliance with the South Carolina Freedom of Information Act and the requirements of the Town of Hilton Head Island.
4. **Roll Call**
5. **Welcome and Introduction to Board Procedures**
6. **Approval of Agenda**
7. **Approval of Minutes** – Meeting of March 25, 2019
8. **Unfinished Business**
9. **New Business**
 - a. **APL-000770-2019** – Request for Appeal from William Peratta with Greenberg Farrow, on behalf of McDonald's. The appellant is appealing staff's determination, dated March 14, 2019, that the proposed digital menu boards for the property located at 2 Plaza Drive are not permitted per the sign standards in the LMO.
10. **Board Business**
 - a. Review and adoption of revised amendments to the Rules of Procedure
11. **Staff Report**
 - a. Waiver Report
12. **Adjournment**

Please note that a quorum of Town Council may result if four (4) or more of their members attend this meeting.

TOWN OF HILTON HEAD ISLAND
Board of Zoning Appeals
Minutes of the March 25, 2019 – 2:30 p.m. Regular Meeting
Benjamin M. Racusin Council Chambers

Board Members Present: Chairman David Fingerhut, Vice Chairman Jerry Cutrer, Patsy Brison, Charles Walczak, Robert Johnson, John White, Lisa Laudermilch

Board Members Absent: None

Council Members Present: None

Town Staff Present: Rocky Browder, Environmental Planner; Nicole Dixon, Development Review Administrator; Brian Hulbert, Staff Attorney; Taylor Ladd, Senior Planner; Teri Lewis, Deputy Director of Community Development; Teresa Haley, Senior Administrative Assistant

1. **Call to Order**
Chairman Fingerhut called the meeting to order at 2:30 p.m.
2. **Pledge of Allegiance to the Flag**
3. **Roll Call**
4. **Freedom of Information Act Compliance**
Public notification of the Board of Zoning Appeals meeting has been published, posted and mailed in compliance with the Freedom of Information Act and the requirements of the Town of Hilton Head Island Land Management Ordinance.
5. **Welcome and Introduction to Board Procedures**
Chairman Fingerhut welcomed the public and introduced the Board's procedures for conducting the business meeting.
6. **Approval of Agenda**
Chairman Fingerhut asked for a motion to approve the agenda. Ms. Brison moved to approve. Mr. Johnson seconded. The motion passed with a vote of 6-0-0.
7. **Approval of the Minutes – Meeting of November 26, 2018**
Chairman Fingerhut asked for a motion to approve the minutes of the November 26, 2018 meeting. Vice Chairman Cutrer moved to approve. Mr. Walczak seconded. The motion passed with a vote of 6-0-0.
8. **Unfinished Business – None**
9. **New Business**
Mr. White entered the meeting at this time.
 - a. **Public Hearing**

VAR-000329-2019 - Deborah Murphy is requesting a variance from LMO Section 16-6-104.F, Specimen Tree Preservation, to remove a specimen sized hickory tree located at the Ocean Course Villas in Sea Pines. The tree is located on Ocean Course Villas Owners Association property located at 108 North Sea Pines Drive between Units 556 and 557. The property is further identified as Parcel # 122A on Tax Map # 17.

Ms. Ladd presented the application as described in the Staff Report. During the statutory publishing period, Staff received three letters in support of the variance. Staff recommends the Board of Zoning Appeals deny the application based on the Findings of Fact and Conclusions of Law contained in the Staff Report. If the Board of Zoning Appeals contemplates approval, Staff recommends the following conditions:

1. The hickory tree shall be mitigated as per LMO requirements at one tree per ten-inches removed. Specifically, mitigating this hickory would require two (2) Category I or Category II trees be planted in the property common area that are at least 2-inch caliper and 10-feet in height. Or, one (1) 4-inch caliper Category I or Category II tree may be planted.
2. Prior to removal, the applicant shall obtain a Natural Resources Permit and provide a tree mitigation and landscape plan for Staff approval with the permit application.

Chairman Fingerhut asked the Board for comments and inquiries to Staff. The Board made comments and inquiries regarding: the age, lifespan, and size of the subject tree; consideration of exemptions listed in LMO Section 16-6-104.B.2; under what conditions the Town would approve the application; the subject tree is on the HOA property; the HOA provided an owner affidavit and authorized removal of the subject tree; other hickory trees in the area overhang parking; and a process question pertaining to consideration of surrounding property owners' letters.

Chairman Fingerhut asked if the applicant would like to make a presentation. Ms. Deborah Murphy, the applicant, thanked Ms. Ladd for her assistance throughout the variance application process. The applicant presented statements regarding her grounds for the variance and answered questions presented by the Board.

Chairman Fingerhut asked the Board for comments and inquiries to the applicant. The Board made comments and inquiries regarding: the damage that occurred to the applicant's vehicle; HOA provides weekly maintenance on the property; the applicant performs own maintenance on property; the applicant confirmed adherence to mitigation requirements; the applicant hired an arborist to evaluate the tree; possibly parking in the overflow parking area; and the amount of hickory nuts in other nearby parking spaces.

The Board made additional comments and inquiries to Staff regarding: the exemptions listed in LMO Section 16-6-104.B.2; and mitigation requirements and process.

Chairman Fingerhut opened the meeting for public comments. One member of the public expressed sympathy to the applicant, but does not support removal of the subject tree.

The Board further discussed the variance request and the testimony presented today. Upon the conclusion of the discussion, Chairman Fingerhut asked for a motion.

Mr. Walczak moved to *deny* the application based on the Findings of Facts and Conclusions of Law contained in the Staff Report. Mr. White seconded. The motion *failed* with a vote of 3-4-0. (Roll: Walczak, Fingerhut, White – for the motion; Brison, Johnson, Cutrer, Laudermilch – against the motion.)

Vice Chairman Cutrer moved to *approve* the application with the conditions set forth below and the following Findings of Facts and Conclusions of Law:

Criteria 1: There are extraordinary and exceptional conditions pertaining to the particular piece of property (LMO Section 16-2-103.S.4.a.i.01):

- The subject tree canopy overhanging the Unit 557 entryway and parking space is a unique condition and meets this criteria.

Criteria 2: These conditions do not generally apply to other properties in the vicinity (LMO Section 16-2-103.S.4.a.i.02):

- The conditions stated in Criteria 1 do not apply to other properties in the vicinity. This criteria is met.

Criteria 3: Because of these conditions, the application of this Ordinance to the particular piece of property would effectively prohibit or unreasonably restrict the utilization of the property (LMO Section 16-2-103.S.4.a.i.03):

- Because of these conditions, the application of the Ordinance would unreasonably restrict the utilization of the property.
- The applicant demonstrated they have suffered personal property damage and they are exposed to certain risks entering and leaving their unit because of the tree.

Criteria 4: The authorization of the Variance will not be of substantial detriment to adjacent property or the public good, and the character of the zoning district where the property is located will not be harmed by the granting of the Variance (LMO Section 16-2-103.S.4.a.i.04):

- The authorization of this variance will not be a detriment to adjacent property.
- The character of the zoning district will be mitigated by the planting of mitigation trees.

Conditions of Approval:

1. The hickory tree shall be mitigated as per LMO requirements at one tree per ten-inches removed. Specifically, mitigating this hickory would require two (2) Category I or Category II trees be planted in the property common area that are at least 2-inch caliper and 10-feet in height. Or, one (1) 4-inch caliper Category I or Category II tree may be planted.
2. Prior to removal, the applicant shall obtain a Natural Resources Permit and provide a tree mitigation and landscape plan for staff approval with the permit application.

Mr. Johnson seconded. The motion *passed* with a vote of 4-3-0. (Roll: Brison, Johnson, Cutrer, Laudermilch – for the motion; Walczak, Fingerhut, White – against the motion.)

10. Board Business

- a. Review of proposed amendments to the Rules of Procedure

Staff made changes to the rules based on the feedback given at the last meeting. The Board and public made comments on those changes. Upon the conclusion of the discussion, the Board asked Staff to incorporate the changes and present at the next regularly held meeting.

11. Staff Report

- a. Update on APL-000942-2018 – 17 Trail Beach Manor Cat Sanctuary

Ms. Lewis presented an in depth update. The Board expressed concerns with the information presented and their expectations of the BZA decision on this case. Staff will look into the Board's concerns discussed today and report back.

- b. Update on Circuit Court Cases

Ms. Dixon reported the update. The Board requested Staff to provide reports on cases as they arise, as opposed to annual updates.

- c. Waiver Report – The Waiver Report was included in the Board's packet.

12. Adjournment

The meeting was adjourned at 4:22 p.m.

Submitted by: Teresa Haley, Secretary

Approved:

David Fingerhut, Chairman



TOWN OF HILTON HEAD ISLAND

Community Development Department

TO: Board of Zoning Appeals
VIA: Shawn Colin, AICP, *Director of Community Development*
FROM: Teri B. Lewis, AICP, *Deputy Director of Community Development*
DATE: April 8, 2019
SUBJECT: APL-000770-2019

Staff has received an appeal from William Peratta with GreenbergFarrow, on behalf of McDonald's. Mr. Peratta is appealing staff's determination, dated March 14, 2019, that the digital menu board signs proposed to be located at 2 Plaza Drive do not comply with the Town's sign standards in the LMO (Land Management Ordinance).

Per the Code of Laws of South Carolina, specifically 6-29-800.B, upon receipt of an appeal, staff is required to immediately transmit to the board all the papers constituting the record upon which the action appealed from was taken. The record as attached consists of the following documents:

- Attachment A - Appellant Submittal
- Attachment B - Staff Determination Letter
- Attachment C - Determination Request
- Attachment D - Vicinity Map

Staff reserves the right to submit additional documents.

Please contact me at (843) 341-4698 or at teril@hiltonheadislandsc.gov if you have any questions.



Town of Hilton Head Island
Community Development Department
One Town Center Court
Hilton Head Island, SC 29928
Phone: 843-341-4757 Fax: 843-842-8908
www.hiltonheadislandsc.gov

FOR OFFICIAL USE ONLY	
Date Received:	_____
Accepted by:	_____
App. #: APL	_____
Meeting Date:	_____

Applicant/Agent Name: William Peratta Company: GreenbergFarrow
Mailing Address: 1430 W. Peachtree St. NW, Suite 200 City: Atlanta State: GA Zip: 30309
Telephone: 678-427-5138 Fax: _____ E-mail: wperatta@greenbergfarrow.com

APPEAL (APL) SUBMITTAL REQUIREMENTS

If you are interested in submitting your appeal electronically please call 843-341-4757 for more information.

The following items must be attached in order for this application to be complete:

- A detailed narrative stating the Town Official or Body who made the decision, the date of the decision being appealed, the decision being appealed, the basis for the right to appeal, the grounds of the appeal, cite any LMO Section numbers relied upon; **and** a statement of the specific decision requested of the review body.
- Any other documentation used to support the facts surrounding the decision.
- Filing Fee - \$100.00 cash or check made payable to the Town of Hilton Head Island.

To the best of my knowledge, the information on this application and all additional documentation is true, factual, and complete. I hereby agree to abide by all conditions of any approvals granted by the Town of Hilton Head Island. I understand that such conditions shall apply to the subject property only and are a right or obligation transferable by sale.

I further understand that in the event of a State of Emergency due to a Disaster, the review and approval times set forth in the Land Management Ordinance may be suspended.

Applicant/Agent Signature:  Date: 3/28/19

March 27, 2019

Ms. Nicole Dixon, CFM
Development Review Administrator
Community Development
Town of Hilton Head Island
One Town Center Court
Hilton Head Island, SC 29928

Re: McDonald's Drive-Thru Digital/LED Menu Boards - Appeal to Allow Installation of LED Menu Boards

Dear Ms. Dixon:

McDonald's would like to appeal the determination to not allow McDonald's to have LED/Digital Outdoor Menu Boards at its drive-thru per the letter from you dated March 14, 2019, and requests that the Board of Zoning Appeals reconsider that decision and allow installation of said LED menu boards.

McDonald's would like to install two (2) LED menu boards at the drive-thru where menu boards currently exist behind the restaurant. The first menu board would be a "pre-browse" menu board with a screen size display area of 9 SF and measure 26.8" in width and 47.7" in height (55" diagonal). The second menu board, the primary ordering menu board, would include two (2) of these screens with a total display area of 18 SF. For comparison purposes, the existing primary ordering menu board at the McDonald's restaurant on the southern end of the island measures 43 SF in area (63.5" in height and 99" in width). Thus, the proposed LED menu boards are significantly less in area, approximately 20% and 42%, respectively.

Please note that McDonald's is currently in the process of preparing to remodel it's restaurant, and has applied to the Design Review Board for approval of the building elevations, to be followed by construction documents for permitting. These menu boards would be installed as part of the remodel, if approved. The statements made in the determination letter that denies the digital/LED signs are reiterated below with responses that address the concerns.

- A. As stated in Ms. Dixon's letter, *"The purpose of the Town's sign standards is to protect, preserve, and enhance the unique aesthetic character beauty, and charm of the Town. The regulations are intended to encourage the construction of commercial signs of high-quality materials that are aesthetically pleasing and are compatible with their natural surroundings. While there is value in having commercial signage as a means of locating and identifying commercial establishments, the sign regulations in the Land Management Ordinance (LMO) are meant to discourage the use of commercial signage to sell goods and services and to eliminate a distracting atmosphere that can result by the physical and visual clutter caused by the signs."*
- Sec.16-5-114. - Sign Standards, Para. A – Purpose, lists several goals this section is intended to achieve. The stated purposes include deterring signs from peddling commodities or services,

encourage quality construction, preventing an “advertising war” by businesses through aggressive advertising while improving safety and removing visual clutter due to distracting signage.

- The menu boards at the ordering kiosks in the drive-thru are simply devices intended to assist customers in confirming their orders and are not an advertising channel or billboard. They are designed to be one component of an ordering system which streamlines and facilitates the customer’s ordering experience. In that function they are no different than the order stations and menu boards internal to the store.
- Additionally, the menu boards are located behind the restaurant and not visible from US Hwy. 278. They are not intended to identify the commercial establishment and its location; this purpose is fulfilled by the existing freestanding sign at the corner of Plaza Drive and U.S. Hwy. 278.
- In order to soften the appearance of the LED menu boards and help them blend into the surrounding environment, we propose to house the menu board in a kiosk. The proposed order kiosks which house the menu boards are constructed with the same materials (or wood), colors and design as the main building to ensure a compatible appearance. Using similar materials and designs allows us to create a more unified and subdued environment. By design, the menu boards are to be as simple as possible without gimmicks or irrelevant material that would hinder a smooth ordering process. Please refer to the attached exhibit that depicts the kiosk with the LED menu board.
- The new digital menu boards are designed, above all, to improve customer experience by improving the drive-thru ordering process. They have increased readability – an important consideration for expediting orders and in serving in an aging demographic - due to the digital technology and having closer placement to drivers. The technology also allows for reduced glare, automatically adjusting brightness based on ambient light. Ordering efficiency is increased resulting in a reduction in queuing lines and vehicle idling times.

B. As stated in Ms. Dixon’s letter, *Per LMO Section 16-5-114.1.2, Prohibited Signs, the following types of signs are prohibited: “Signs with animated or moving effects (including but not limited to sign faces that periodically change to show different images or messages), and signs carried, waved, or otherwise displayed by persons either on public ways or in a manner visible from public ways are prohibited. This provision is directed toward such displays intended to draw attention for a commercial purpose, and is not intended to limit the display of placards, banners, flags, or other signage by persons participating in demonstrations, political rallies, and similar events.”*

Digital signage, by definition, is where video or multimedia content is displayed for informational or advertising purposes. As a digital sign or menu board contains animated or moving effects, it would be classified as a prohibited sign per the LMO.

- As stated above, menu boards are intended as aids to help customers finalize their orders. They are a component of a system devised to process and complete a customer’s order in the most expeditious manner possible. Menu boards are not designed to entice, persuade or attract customers into McDonald’s, nor are they proposed to be visible from public streets. Their purpose is not to act as a way-faring device to inform travelers a McDonald’s is located at that site. Once a customer has reached a position to view a menu board they have completed their decision-making process to enter McDonald’s for a meal and continue through the drive-thru lane to qualify and place their order.
- In the above review comment it is definitively stated “a digital sign or menu board contains animated or moving effects”. The McDonald’s Outdoor Digital Menu Board does not display animated or

moving effects. They do not have flashy bright images or colors and do not contain animation. The menu boards are merely a static display of menu items and prices. It is simply a picture of what is being offered. A garish or ornate, even entertaining, display would be counter-productive because it would distract drivers in the drive-thru lane, thereby slowing the entire process.

- Regarding the code section about “*sign faces that periodically change*,” the only display change occurs when the meal time menu changes – which is two or three times during a 24-hour period. This change is from breakfast to lunch/dinner, and then lunch/dinner to breakfast (lunch and dinner share the same menu). This change occurs as quickly and unobtrusively as changing the channel on your home television. Again, that is the only time the message/menu order items “*periodically change*”.

C. *Per LMO Section 16-5-114.D.5, Sign Illumination, internal illumination for menu board signs for eating establishments with a drive-through are permitted provided they do not cause glare hazardous to pedestrians or vehicle drivers or so as to create a nuisance to adjacent properties. Such signs shall be placed and angled so that, to the greatest extent possible, they are not visible from public or private streets.*

- The menu board units are recessed into the order kiosks several inches which helps in shielding the screens from anything but a direct view with the possibility of a 45-degree to 60-degree angle view from Plaza Dr., and a partial view thorough the existing landscape buffer from the adjacent Jiffy Lube business. Please refer to the attached exhibit showing the view angle from Plaza Drive.
- Locating the kiosk behind the store and angling the kiosks away from Plaza Drive, along with careful placement of landscape elements along Plaza Drive and the proposed landscape buffer along the property boundary with Jiffy Lube, the order kiosks will be screened from view as much as possible. No hazardous glare will be directed toward motorists and with a proposed landscaped buffer along the property boundary, with Jiffy Lube, the signs will not be a nuisance. Because the area of the primary LED menu board is approximately 40 to 50 percent smaller than the current primary ordering menu board, it inherently has a reduced visual footprint.

D. *LED is a type of light source, or illumination. As long as LED menu boards meet the conditions provided in Section 16-5-114.D.5, they would be permitted.*

- As described above in item C, and as proposed, the menu boards would meet the conditions specified in Section 16-5-114.D.5, and as such, we believe they should be permitted.

Attached are exhibits showing the proposed LED menu boards, proposed kiosk, and the existing four-panel menu board at the McDonald’s on the southern end of the island. Thank you for your consideration.

Sincerely,



William Peratta

EXTERIOR FINISH SCHEDULE	
COLOR SCHEME: 'CRAFTSMAN'	
BUILDING ITEMS	DESCRIPTION
METAL ROOF	STANDING SEAM METAL ROOF BY ENGLERT COLOR: CHARCOAL GRAY
STUCCO	EXISTING STUCCO TO REMAIN NEW STUCCO PAINTED BENJAMIN MOORE "OCTOBER SKY" 2162-70 TO MATCH EXISTING BUILDING
BRICK VENEER	AUTHINTIC BRICK BY MERIDIAN BRICK COLOR: SAVANNAH GRAY

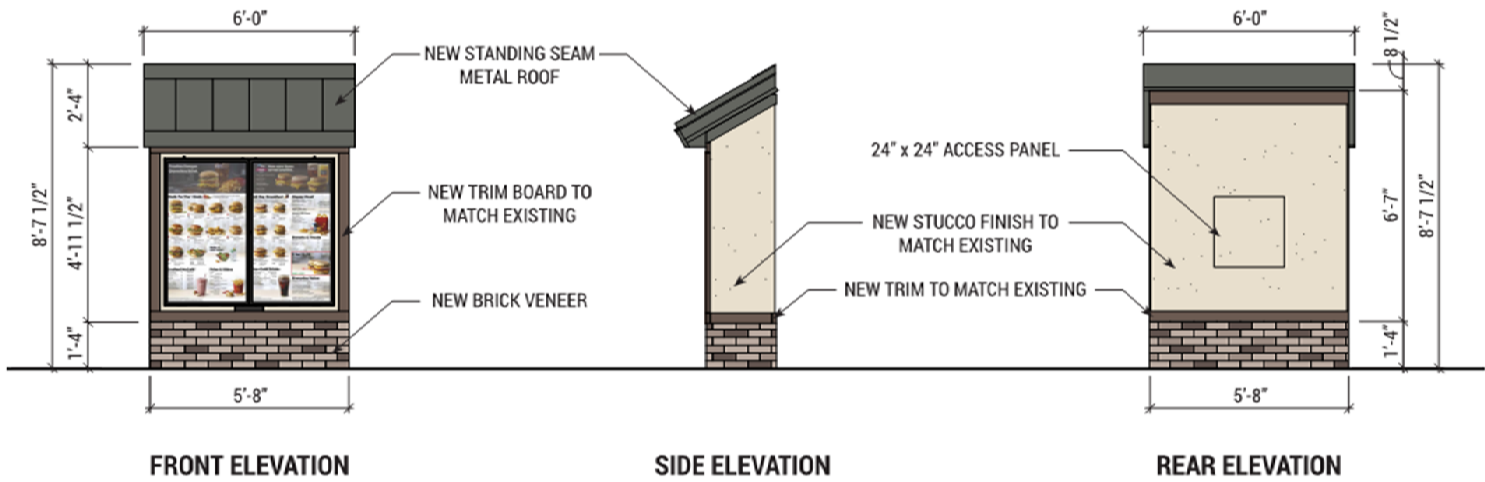

ORDER KIOSK WITH LED MENU BOARDS

EXHIBIT A



EXHIBIT B

EXAMPLE OF LED MENU BOARD

McDonald's
 Hilton Head Island, SC

Area of display

Area of display



EXHIBIT C

LED MENU BOARDS - AREA OF DISPLAY

McDonald's

Hilton Head Island, SC



EXHIBIT D

EXISTING ORDER KIOSK WITH PAPER MENU BOARDS AT 50 NEW ORLEANS RD.

McDonald's
Hilton Head Island, SC

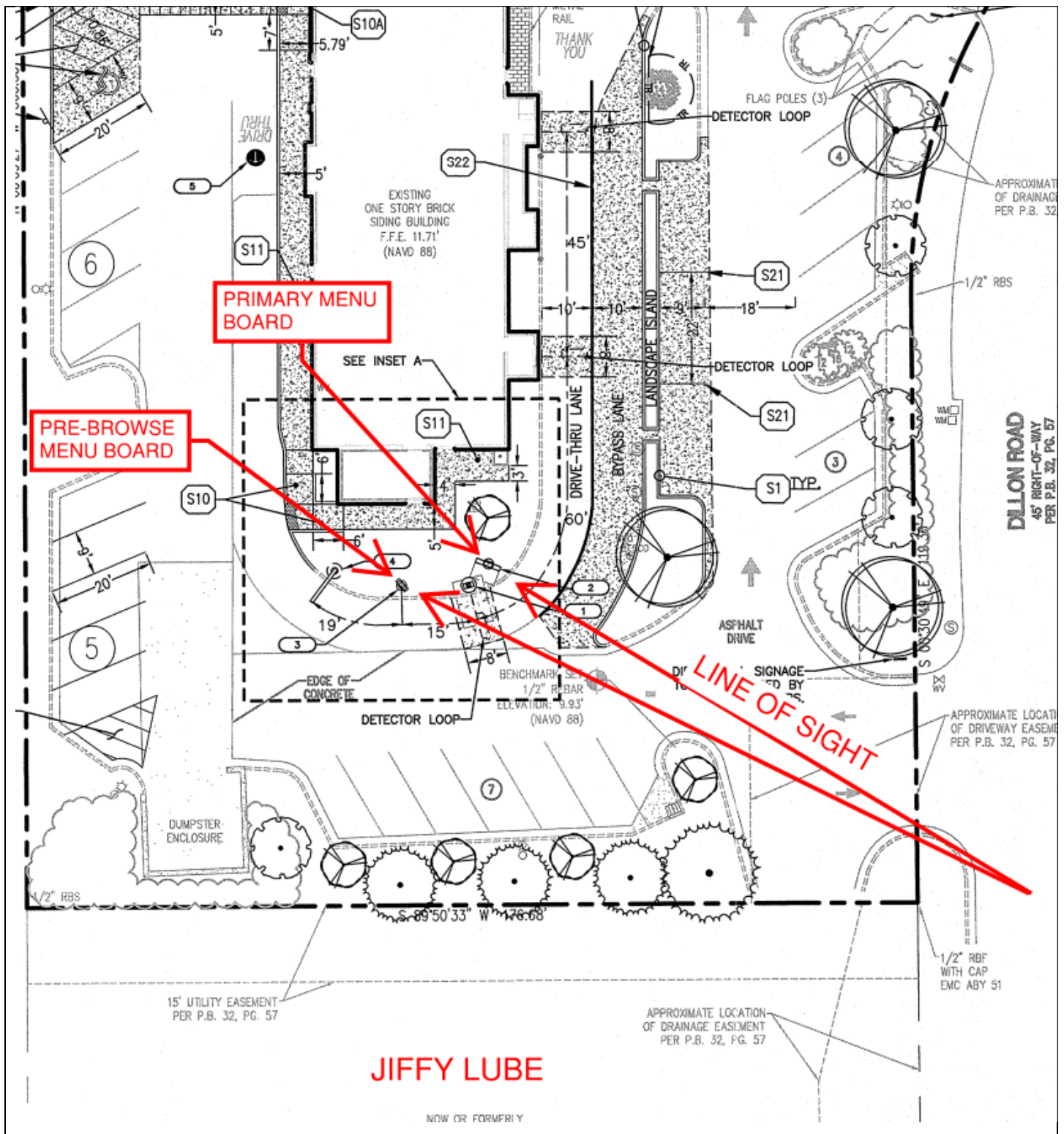

JIFFY LUBE

NOW OR FORMERLY

EXHIBIT E

LINE OF SIGHT

McDonald's

Hilton Head Island, SC

Attachment B

John J. McCann
Mayor

William D. Harkins
Mayor ProTem

Council Members

David Ames
Tamara Becker
Marc A. Grant
Thomas W. Lennox
Glenn Stanford

Stephen G. Riley
Town Manager

Via E-mail

March 14, 2019

Mr. William Peratta, AICP
Greenberg Farrow
1430 West Peachtree Street, NW
Suite 200
Atlanta, GA 30309

Dear Mr. Peratta:

This letter is in response to your letter dated February 25, 2019 requesting a formal determination regarding your proposed signs. Specifically, you are inquiring if digital or LED menu boards are permitted to replace the menu boards that are currently located within the drive-through, as part of the redevelopment of the McDonald's at 2 Plaza Drive.

The purpose of the Town's sign standards is to protect, preserve, and enhance the unique aesthetic character, beauty, and charm of the Town. The regulations are intended to encourage the construction of commercial signs of high-quality materials that are aesthetically pleasing and are compatible with their natural surroundings. While there is value in having commercial signage as a means of locating and identifying commercial establishments, the sign regulations in the Land Management Ordinance (LMO) are meant to discourage the use of commercial signage to sell goods and services and to eliminate a distracting atmosphere that can result by the physical and visual clutter caused by signs.

Per LMO Section 16-5-114.I.2, Prohibited Signs, the following types of signs are prohibited: "Signs with animated or moving effects (including but not limited to sign faces that periodically change to show different images or messages), and signs carried, waved, or otherwise displayed by persons either on public ways or in a manner visible from public ways, are prohibited. This provision is directed toward such displays intended to draw attention for a commercial purpose, and is not intended to limit the display of placards, banners, flags, or other signage by persons participating in demonstrations, political rallies, and similar events."

Digital signage, by definition, is where video or multimedia content is displayed for informational or advertising purposes. As a digital sign or menu board contains animated or moving effects, it would be classified as a prohibited sign per the LMO.

Per LMO Section 16-5-114.D.5, Sign Illumination, internal illumination for menu board signs for eating establishments with a drive-through are permitted provided they do not cause glare hazardous to pedestrians or vehicle drivers or so as to create a nuisance to

adjacent properties. Such signs shall be placed and angled so that, to the greatest extent possible, they are not visible from public or private streets.

LED is a type of light-source, or illumination. As long as the LED menu boards meet the conditions provided in Section 16-5-114.D.5, they would be permitted.

Should you wish to appeal this determination to the Board of Zoning Appeals (BZA), you must file an appeal application within 14 calendar days of receipt of this determination.

Should you have any other questions or concerns, please contact me at (843) 341-4686 or nicoled@hiltonheadislandsc.gov.

Sincerely,

A handwritten signature in cursive script that reads "Nicole Dixon".

Nicole Dixon, CFM
Development Review Administrator



1430 West Peachtree Street, NW
Suite 200
Atlanta, GA 30309
404.601.4000
www.greenbergfarrow.com
We Are Global

February 25, 2019

Ms. Nicole Dixon, CFM
Development Review Administrator
Community Development Department
Town of Hilton Head Island
One Town Center Court
Hilton Head Island, SC 29928

Re McDonald's 2 Plaza Dr. – Request for Digital Menu Board Signs

Dear Ms. Dixon:

As part of McDonald's remodeling efforts for the restaurant at 2 Plaza Drive, McDonald's would like to install digital or LED menu boards in accordance with those shown in "Exhibit A," submitted herewith.

Two (2) digital/LED signs are proposed to be installed. One (1) sign would be the pre-browse board, approximately 10 SF in size; and the other would be a two-panel menu board, approximately 20 SF in size. Both are further described in Exhibit A and are pictured below.



The signs would be placed behind the store very close to the locations of the exiting menu boards, and the message side of the sign would not be visible from US 278 or Plaza Dr.

On behalf of McDonald's USA, LLC, thank you for your consideration.

Sincerely,

William Peratta, AICP
GreenbergFarrow



EXHIBIT A



McDonald's - 2 Plaza Drive

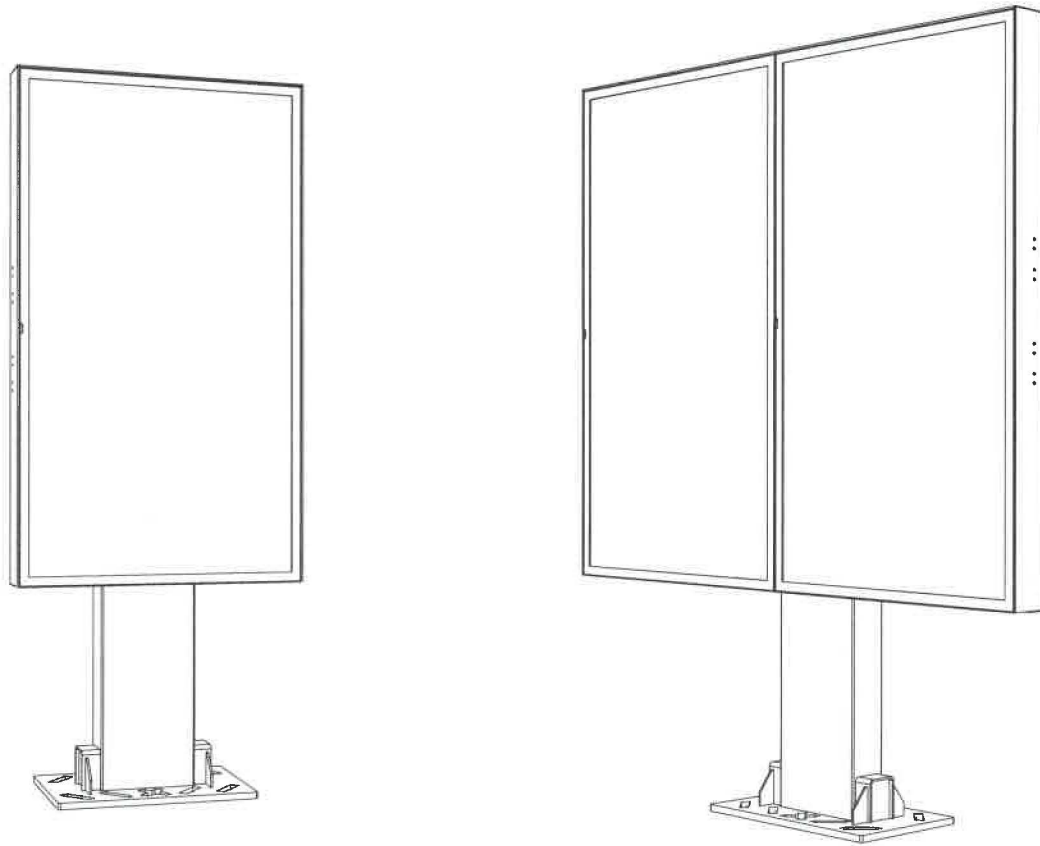

55" Outdoor digital menuboard

02-55-2S/D Outdoor Menu Board

Permitting Unit Information

Version 1.0

Coates ODMB

Single screen unit



Area of display

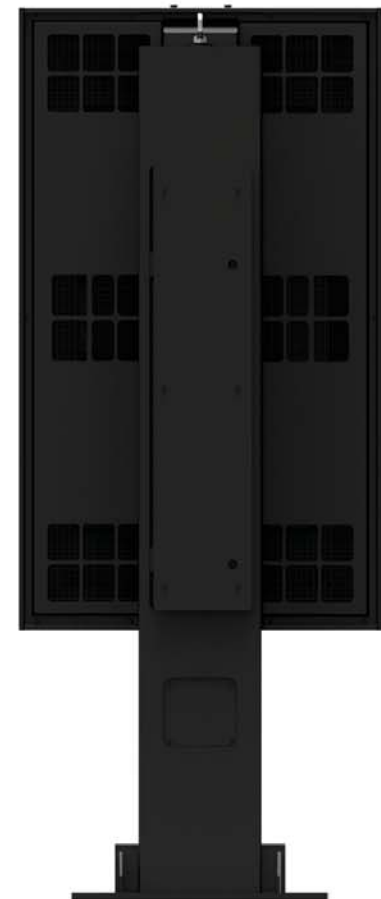
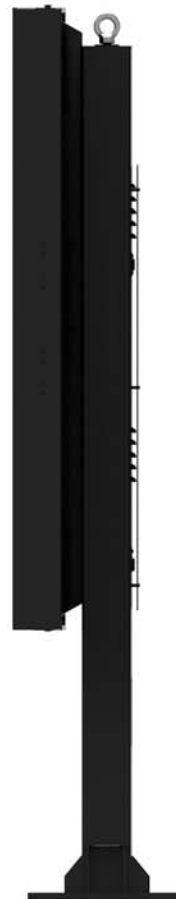

Coates ODMB

Double screen unit



Area of display

Area of display

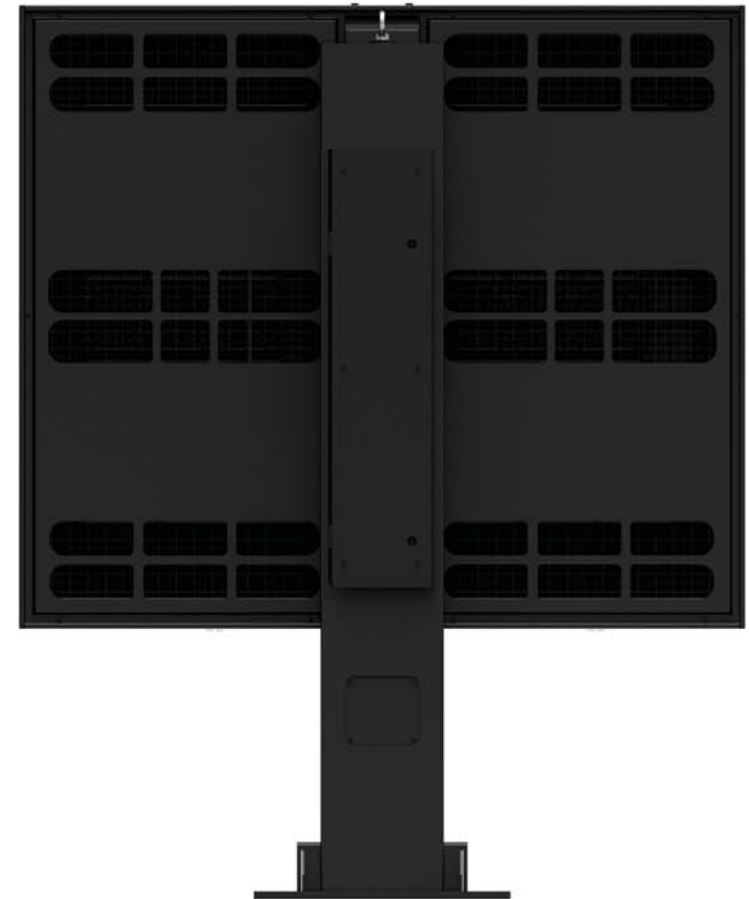

Coates ODMB

Single screen unit

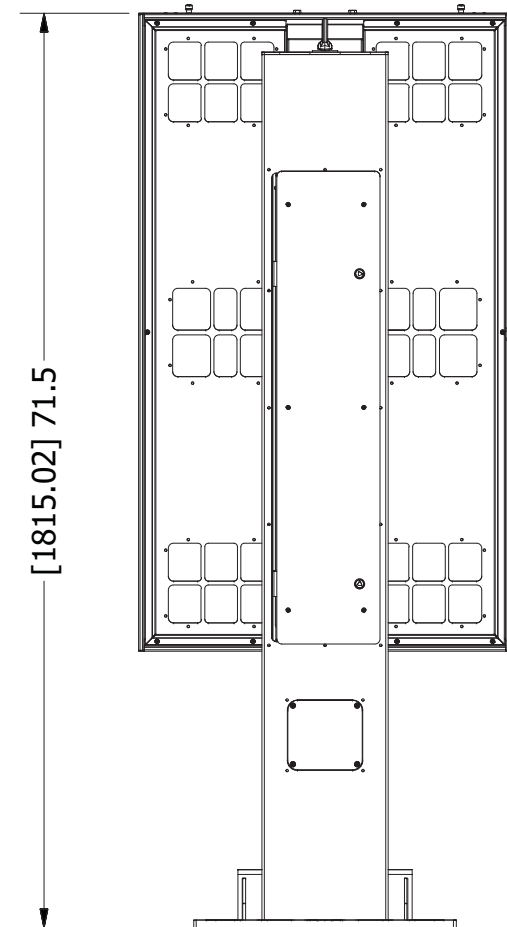
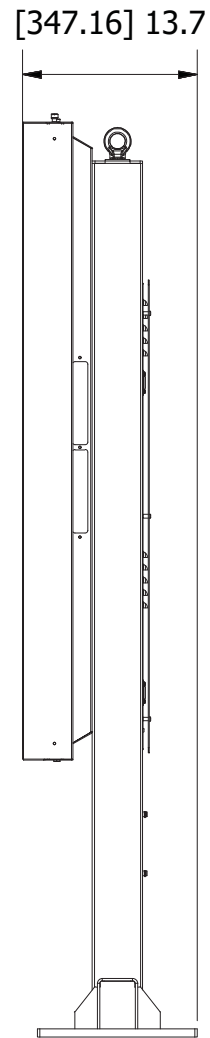
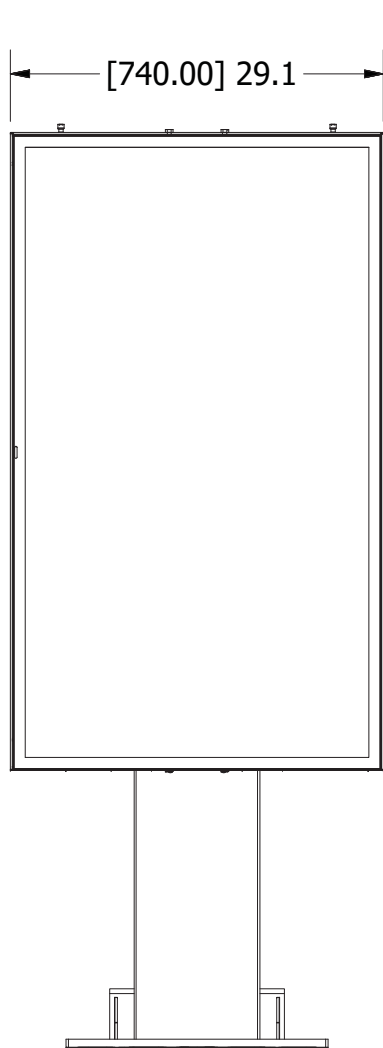

Coates ODMB

Double screen unit

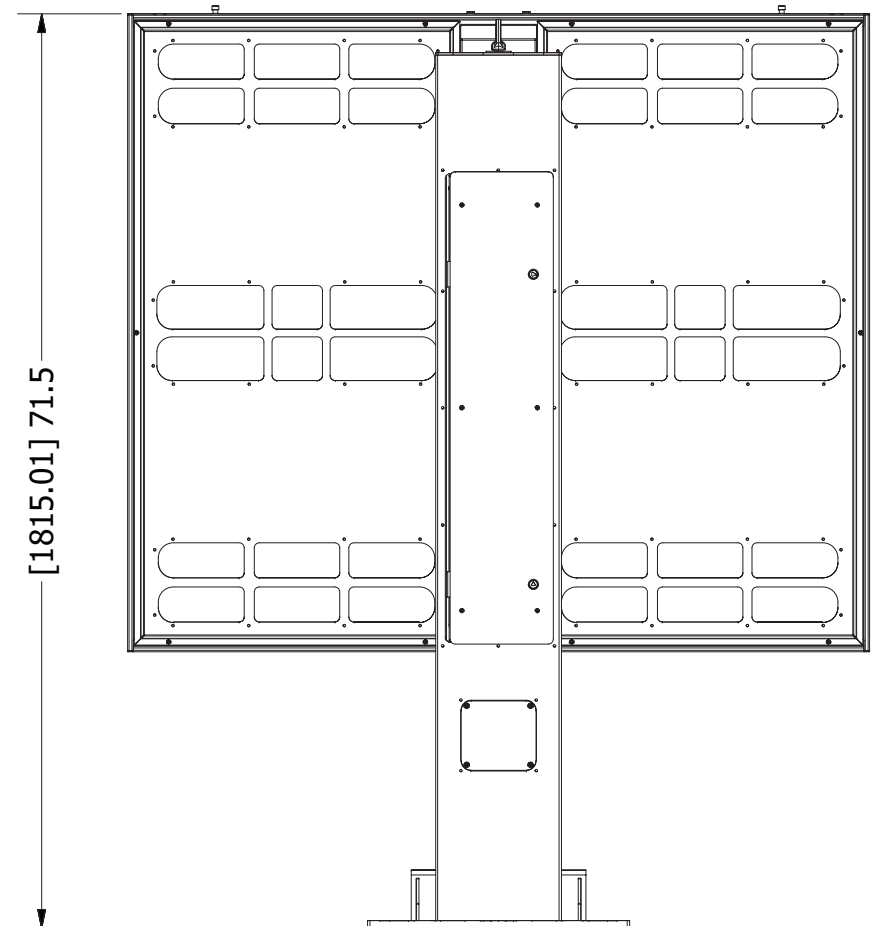
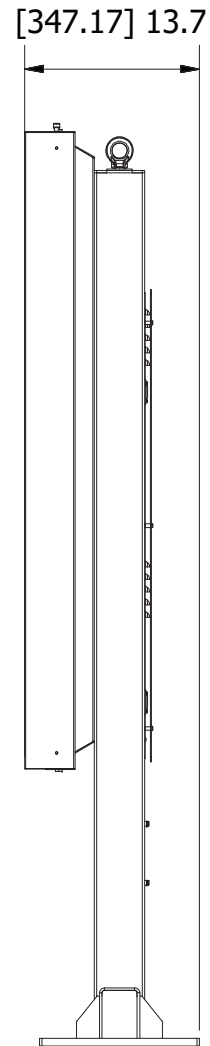
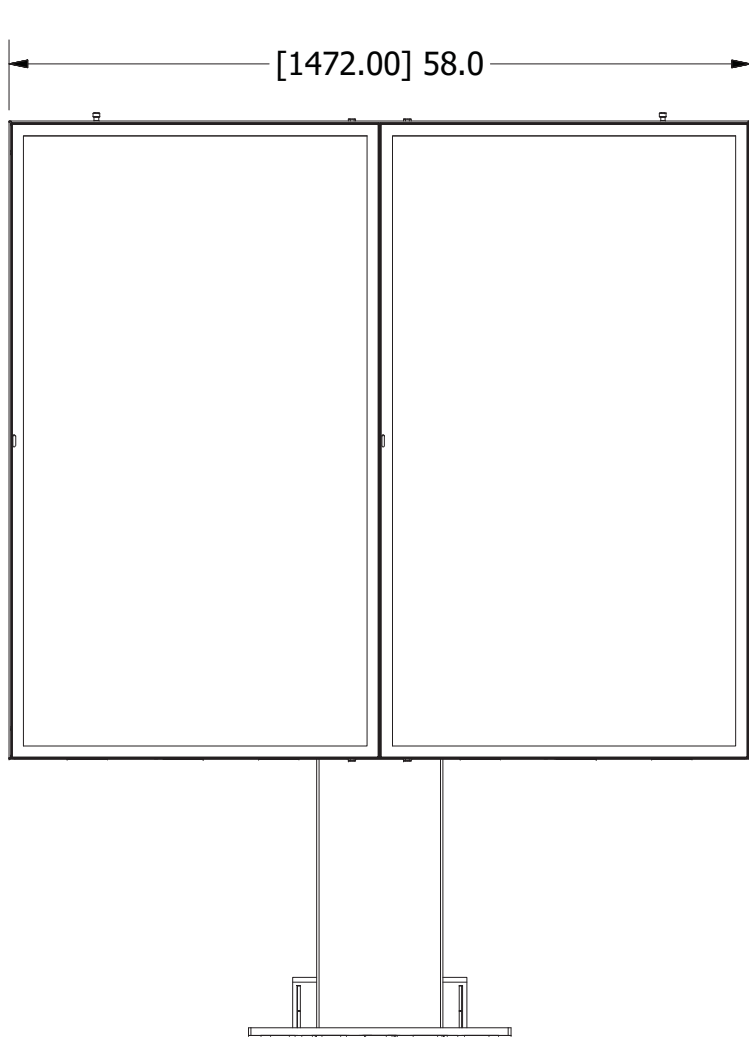

Coates ODMB

Power draw

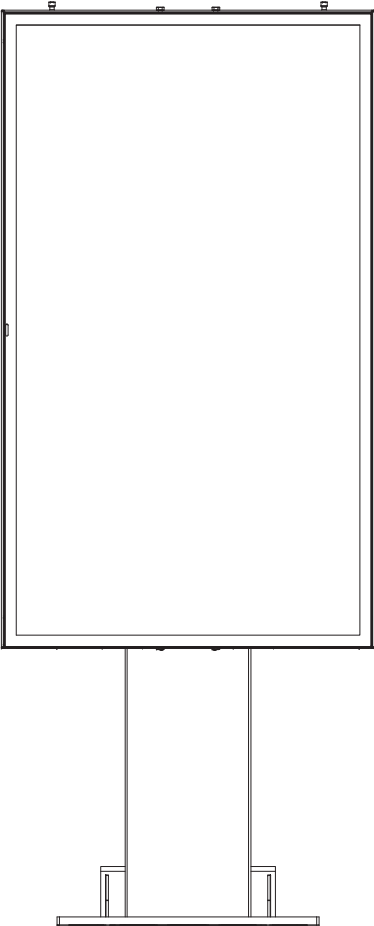

Max potential draw 5.7A @110V

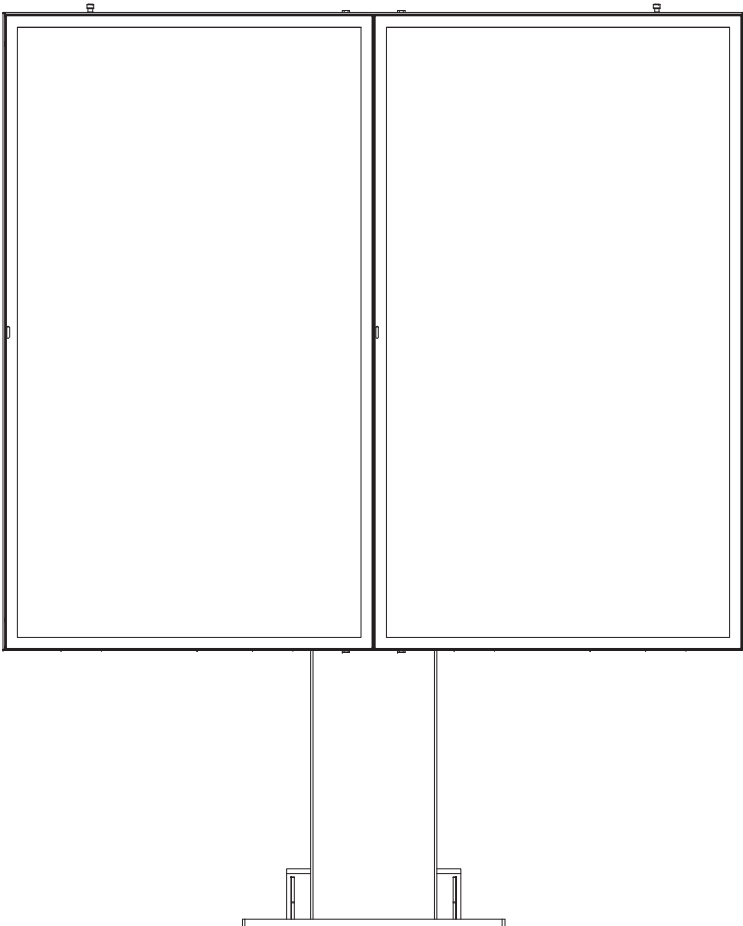

Max potential draw 9.8A @110V



UL48 Electric sign

Coates ODMB

Height variations



Existing design has multiple fixture points already built in for brackets and screens allow for lowering in 2 additional increments.

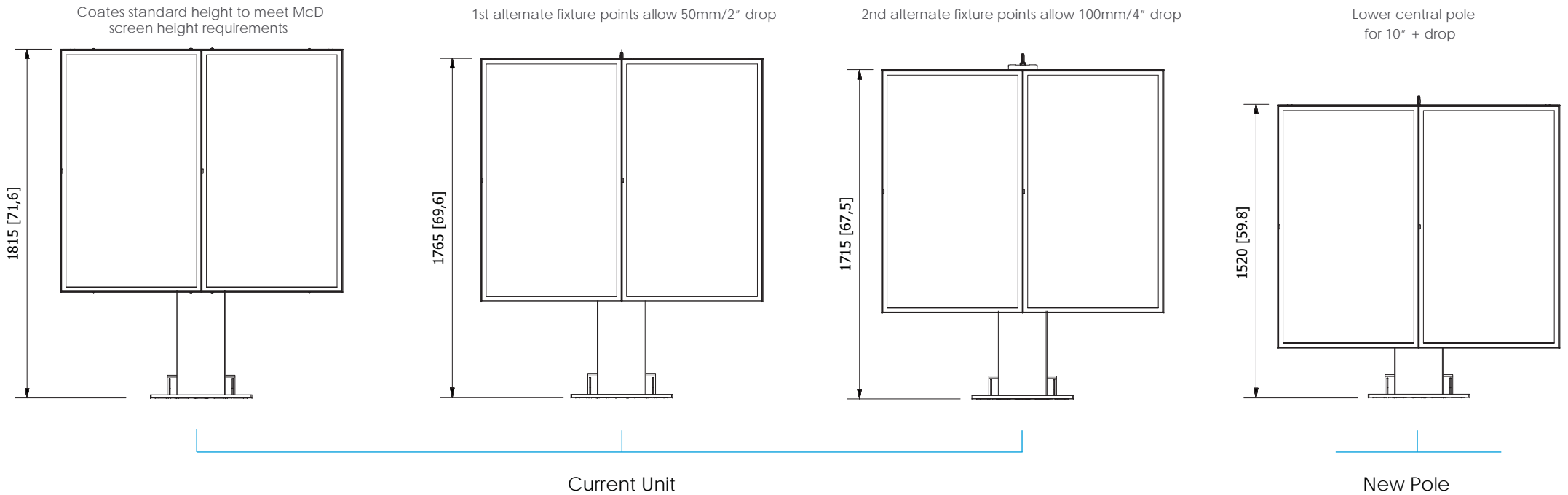

Display specification

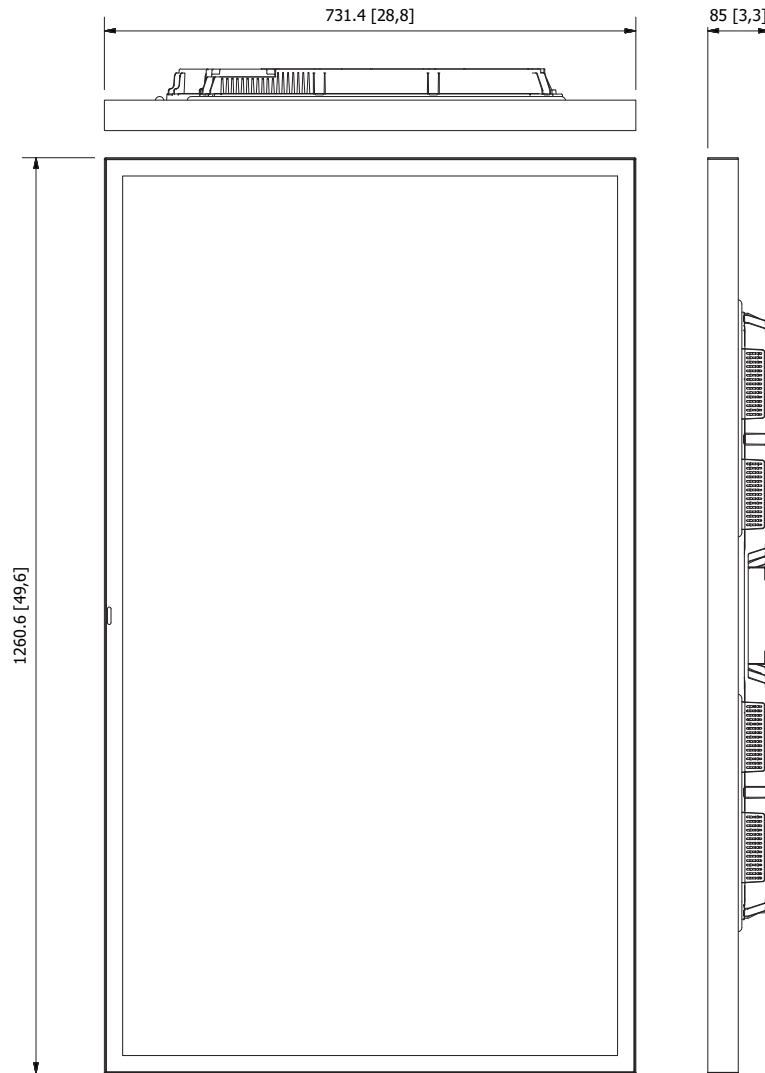

Samsung 550HF

Diagonal Size	55"
Brightness	2500 NIT
Weight	52.6 Kg [118.2 lbs]
Mechanical Specification	
Glass	5T Tempered Glass
Bezel Width	24.9mm [0.98"]
Operation Temperature	-40°C ~ 50 °C [-40 F ~ 122 F]
Certification	UL : CUL60950-1 (GO)

Display specification

Lumen output

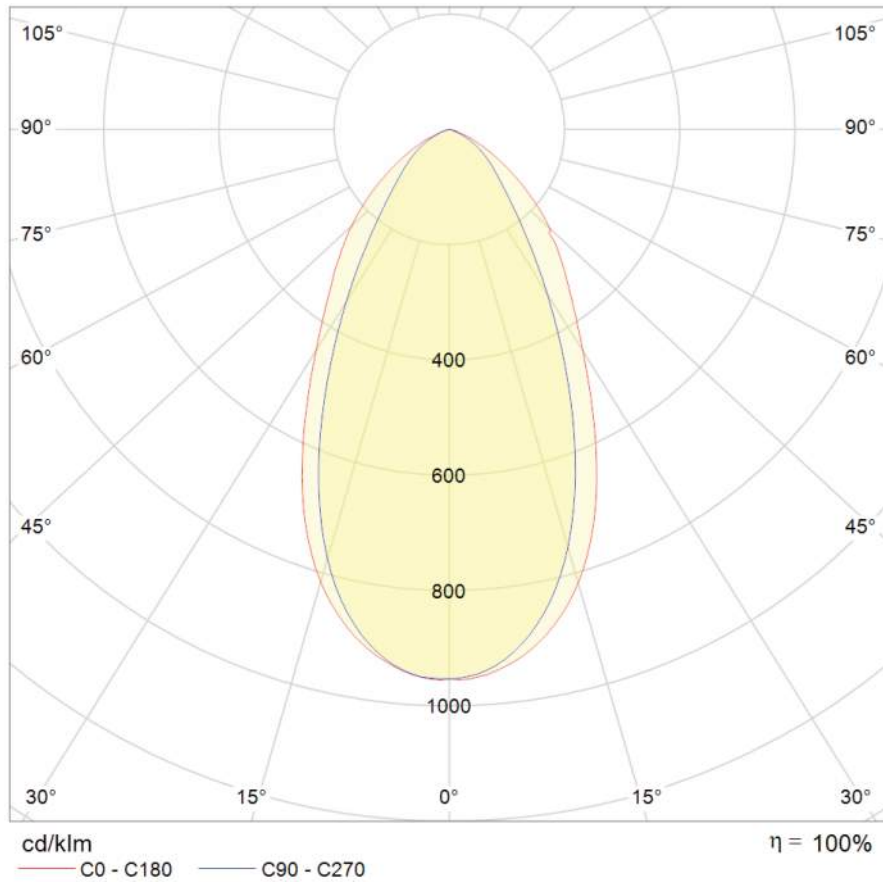

Fig 1.0

The attached is the max potential light output of the screen (see accompanying IES file)

The units have inbuilt ambient light sensors

These light sensors dim the brightness of the screen based on the light surrounding it

The screens can dim from full brightness 2500nit (Fig1.) all the way down to 500nit to prevent excessive output (glare) in low light and night time environments

Coates ODMB

Single with additional security glass

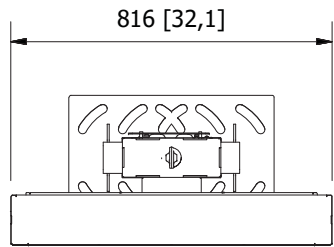

Optional tempered glass security cover
6mm tempered glass

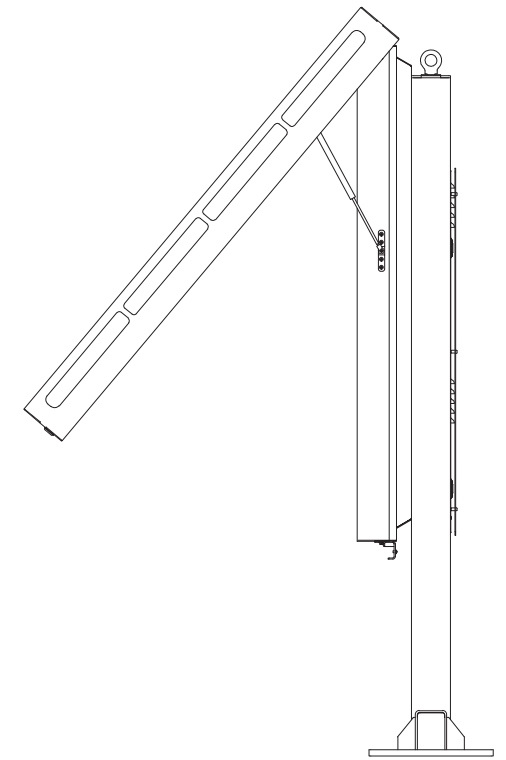
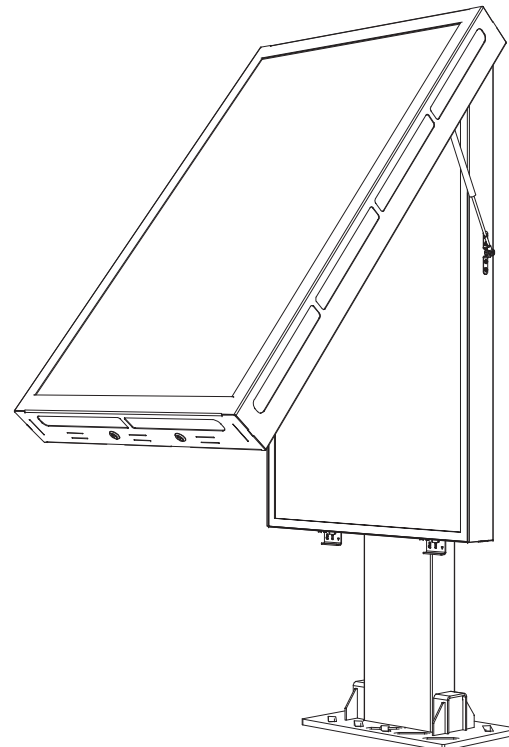
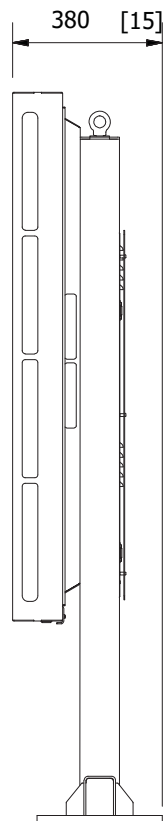
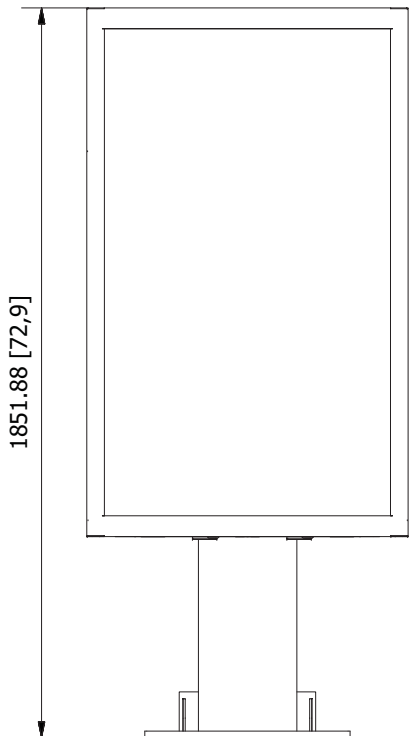

Coates ODMB

Double with additional security glass

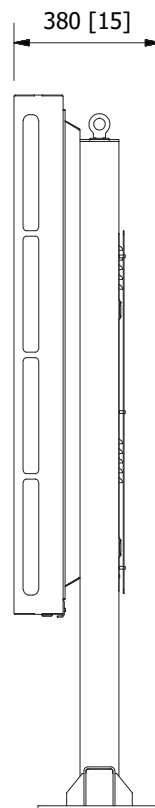
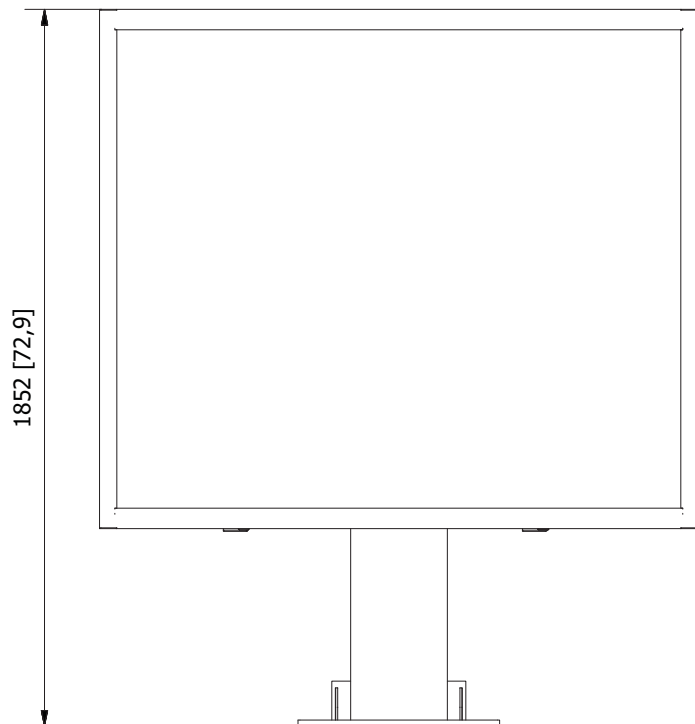
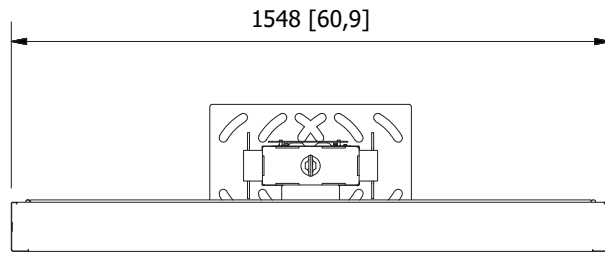

Optional tempered glass security cover
6mm tempered glass

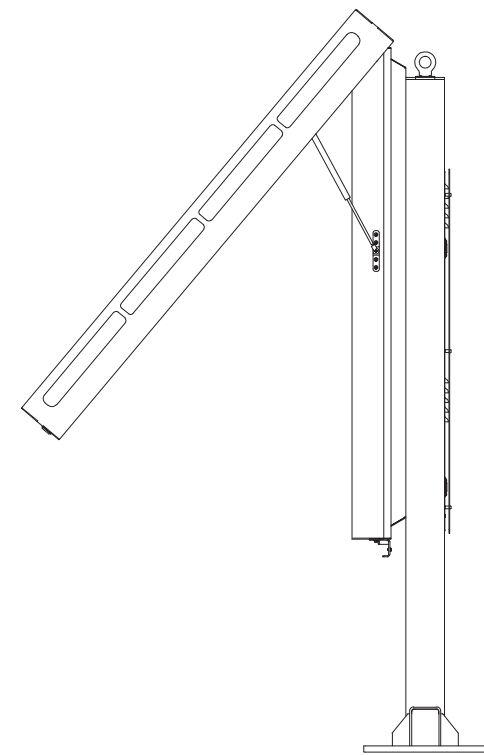
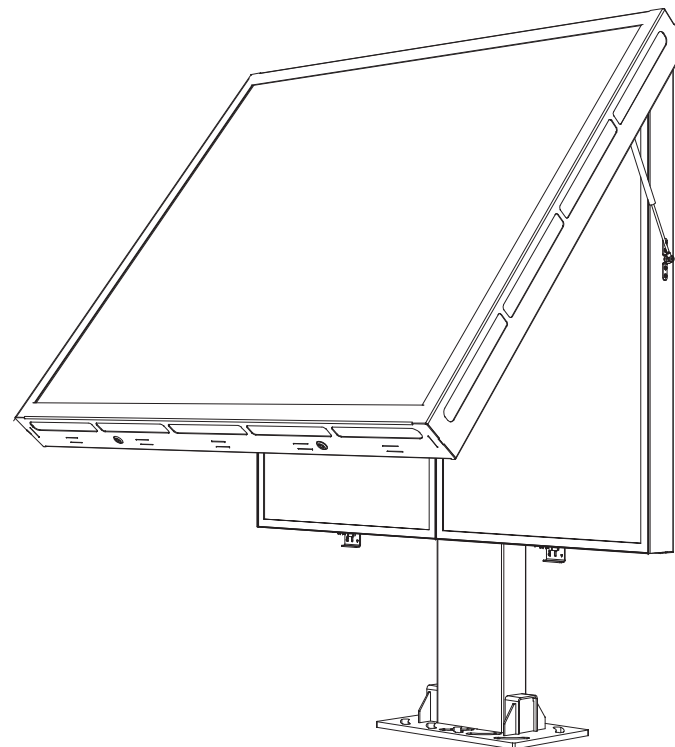

Coates ODMB
Additional security glass



Coates ODMB

Color specification



Unit powder coat color Coates dark grey
Match Pantone: 446C
Gloss specification: 7-12 units @60deg

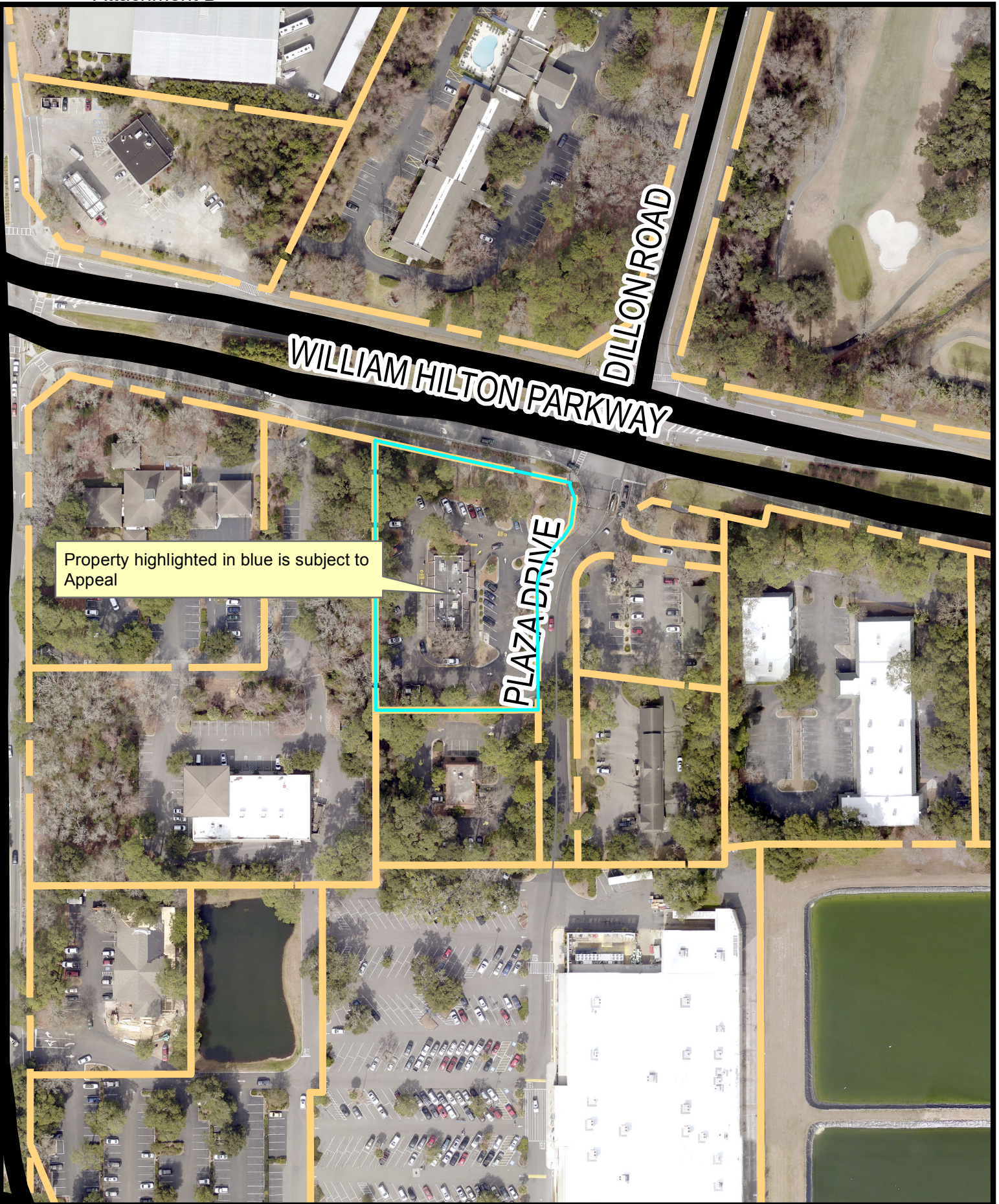

Property highlighted in blue is subject to Appeal

Town of Hilton Head Island
 APL-000770-2019
 Attachment D - Vicinity Map



TOWN OF HILTON HEAD ISLAND
 ONE TOWN CENTER COURT
 HILTON HEAD ISLAND, S.C. 29928
 PHONE (843) 341-1400
 Date Created: November 16, 2017
 Project: map.mf

The information on this map has been compiled from a variety of sources and is intended to be used only as a guide. It is provided without any warranty or representation as to the accuracy or completeness of the data shown. The Town of Hilton Head Island assumes no liability for its accuracy or date of completion or for any losses arising from the use of the map.



TOWN OF HILTON HEAD ISLAND

Community Development Department

TO: Board of Zoning Appeals
FROM: Taylor Ladd, *Senior Planner*
DATE: May 5, 2019
SUBJECT: Revisions to Rules of Procedure

At the March 25, 2018 BZA meeting, the Board reviewed and discussed amendments to the Rules of Procedure as presented by Staff. Based on this discussion, a minor revision has been made. The attached version of the Rules of Procedure is presented for your review.

In the attached document, final revision has been made to:

- Article IX, Section 2, Paragraphs 4 and 6 on page 17

Since the March meeting, a revision has been made to Article IX, Section 2, Paragraphs 4 and 6 as per suggestion by public comment and Board discussion at the meeting, to include “holder of permit or approval” in place of “building permit holder.” Action may be taken to approve the amended Rules of Procedure at the May 20 meeting.

As per the Rules of Procedure Article III, Section 2, *these rules may be amended at any time by an affirmative vote of a majority of the members of the Board; provided however, that such amendment(s) shall have first been presented to the entire Board, in writing, at a Regular or Special Meeting preceding the Regular or Special Meeting at which the vote is taken.*

*Board of Zoning Appeals
Rules of Procedure
Town of Hilton Head Island*

CONTENTS

	Page
Article I: <u>Powers and Responsibilities</u>	4
<hr/>	
Article II: <u>Authority</u>	
Section 1. Authority.	4
Section 2. Territorial Jurisdiction.	4
<hr/>	
Article III: <u>Rules of Procedure</u>	
Section 1. Rules of Procedure.	4
Section 2. Amendment.	5
<hr/>	
Article IV: <u>Board Organization and Duties</u>	
Section 1. Membership.	5
A. Number and Qualifications.	
B. Length of Terms.	
C. Term Limits.	
D. Attendance/Absences.	
E. Removal.	
F. Education.	
Section 2. Election of Officers.	6
A. Chairman – Term and Duties.	
B. Vice-Chairman.	
Section 3. Secretary – Appointment and Duties.	7
Section 4. Staff Board Coordinator.	8
<hr/>	

Article V: <u>Meetings and Quorum</u>	
Section 1. Regular and Special Meetings.	8
A. Meeting Schedule.	
B. Regular Meetings.	
C. Special Meetings.	
D. Cancellation of Meetings.	
Section 2. Quorum.	9
Section 3. Conflict of Interest.	9

Article VI: Meeting Administration, Public Comment, Notices, Fees, Voting Supplemental Submissions/Briefs

Section 1. Media Notices.	10
Section 2. Agenda [Order of Business].	10
Section 3. Minutes.	10
A. Meetings.	
B. Minimum Contents of Minutes.	
C. Lack of Quorum	
Section 4. Public Comment.	11
Section 5. Submission Deadline for Regular Meetings.	11
Section 6. Meeting Protocol.	11
Section 7. Filing of Application, Fees and Notice.	12
Section 8. Motions and Final Decisions.	12
Section 9. Voting.	12
A. General.	
Section 10. Supplemental Submissions/Briefs.	12
Section 11. Communication Among Board Members or With an Outside Party.	13

Article VII: Procedures for Hearing an Application for a Variance

Section 1. Presentation of the Town Staff and Applicant.	13
Section 2. Public Comment.	14
Section 3. Vote on Application for Variance.	14

Article VIII: <u>Procedures for Hearing an Application for Special Exception</u>	
Section 1. Presentation of the Town Staff and Applicant.	14-15
Section 2. Public Comment.	15
Section 3. Vote on Application for Special Exception.	15

Article IX: <u>Procedures for Hearing an Appeal</u>	
Section 1. Jurisdiction.	16
Section 2. Presentation of the <u>Appellant, Town Staff and Applicant, and Interested Parties.</u>	16
Section 3. Vote on the Appeal.	16-17

Article X: <u>Procedures for a Remand</u>	
Section 1. Remand.	17-18

Article XI: <u>Motions</u>	
Section 1. Motion for a Reconsideration.	17-18
Section 2. Motion to Dismiss	18-19
Section 3. Motion for Postponement	18-19
Section 4. Motion for Withdrawal of Application	18-19

Article XII: <u>Miscellaneous</u>	
Section 1. Executive Session	19-20
Section 2. Recess	20-21

<u>Attachments for Reference</u>	
Types of Motions	22
Types of Votes	25

Article I
Purpose and Responsibilities

The Board of Zoning Appeals exists to provide final administrative decisions for the Town of Hilton Head Island to enforce the zoning ordinance in accordance with State law, subject to an appeal to circuit court by an appropriate interested party. Its main responsibilities include hearing and deciding: (a) appeals from administrative decisions of the Land Management Ordinance (LMO) Administrator and from Planning Commission actions on certain traffic analysis plans; (b) applications for variances from LMO requirements; and (c) applications to permit uses by special exception. The powers of the Board of Zoning Appeals also include remanding a matter to an administrative official if the record is deemed insufficient, issuing subpoenas for witness appearances, and certifying contempt to the circuit court. In exercising these powers, the Board of Zoning Appeals may, in conformity with State law and the LMO, reverse or affirm, wholly or in part, or may modify the order, requirements, decision, or determination of an Administrator, and to that end, has all the powers of the officer from whom the appeal is taken and may issue or direct the issuance of a permit. All final decisions and orders of the Board must be in writing and be permanently filed in the office of the Board as a public record.

Article II
Authority

Section 1. Authority.

The Town of Hilton Head Island Board of Zoning Appeals is established by Appendix A-3 of the Land Management Ordinance (LMO) of the Town of Hilton Head Island pursuant to the authority of Section 6-29-780, *et seq.*, of the Code of Laws of South Carolina, and hereinafter shall be referred to as the "Board."

Section 2. Territorial Jurisdiction.

Pursuant to Appendix A-3.E of the LMO, the Board shall have jurisdiction over all the lands within the Town. This jurisdiction may be expanded by the Town Council by ordinance and/or by intergovernmental agreement, in accordance with Section 6-29-330 of the Code of Laws of South Carolina.

Article III
Rules of Procedure

Section 1. Rules of Procedure.

These *Rules of Procedure* are adopted by the Board to carry out its powers and responsibilities under SC Code 6-29-780, -790, -800, and -810 and Appendix A-3 of the LMO. A portion or section of the *Rules of Procedure* may be suspended by majority vote of the Board to meet particular circumstances. If there is a situation where these *Rules of Procedure* do not specifically apply, then the most recent edition of *Robert's Rules of Order* shall govern the conduct of meetings. An informational chart summarizing types of motions and votes in Robert's Rules of Order is attached.

Section 2. Amendment.

These rules may be amended at any time by an affirmative vote of a majority of the members of the Board; provided however, that such amendment(s) shall have first been presented to the entire Board, in writing, at a Regular or Special Meeting preceding the Regular or Special Meeting at which the vote is taken.

Article IV **Board Organization and Duties**

Section 1. Membership.

- A. Number and Qualifications.** The Board shall consist of seven members appointed by the Town Council. To the extent practicable, the appointed members may include at least one attorney and one design professional (either a registered architect or a registered landscape architect). None of the members shall hold an elected public office or position with the Town of Hilton Head Island or Beaufort County, South Carolina.
- B. Length of Terms.** Members of the Board shall be appointed annually for three-year terms effective each July 1, with all such terms ending on June 30 of the applicable year, unless a member is appointed to fill a vacancy. Vacancies shall be filled by the Town Council by appointments for the balance of any unexpired terms.
- C. Term Limits.** No member may serve more than two successive terms, except for extraordinary circumstances where Council believes it to be in the best interest of the community to have a continuation for a specific period of a particular member of the Board. This limitation shall not prevent any person from being appointed to the Board after an absence of one year. Service for a partial term of less than 1½ years shall not constitute a term of service for the purpose of these term limits.
- D. Attendance/Absences.** Board members are expected to attend all Board meetings. Each member of the Board who has prior knowledge that they will not be able to attend a scheduled Regular Meeting of the board shall notify the Secretary no later than 4:30pm the business day before the meeting. In the case of an emergency, a member shall give the earliest possible notification. The Secretary or Staff shall notify the Chairman in the event that the projected absence(s) will produce a lack of a quorum.
- E. Removal.** Three (3) absences at Regular or Special Meetings of the Board during one Board year (July 1 through June 30) shall be cause for recommendation by the Chairman to the Town Council to reconsider the appointment of that member. Attendance records may be reviewed annually by the Board in executive session during the 9th month of each Board year.
- F. Education.** The Code of South Carolina requires a six (6) hour Orientation Program and a three (3) hour/year Continuing Education Program for each Board member.

Section 2. Election of Officers.

The officers of the Board shall be a Chairman and a Vice-Chairman for one-year terms beginning on the first meeting in July. They are elected annually by the Board members no later than at the last meeting in July. Neither of these two positions shall be filled by a member beginning his or her first year of service as a Board member. Members that leave the Board and are re-appointed after a period of no more than three years may be elected to an officer position in his or her first year of service. Nominations for the Chairman and Vice-Chairman shall be made from the floor at the meeting.

A majority vote is normally required to elect to office. If no one in an election receives a majority vote, the vote must be repeated until one of them does get a majority.

A. Chairman – Term and Duties. The term shall be for one year. At the end of each Board year, the Chairman may be re-elected subject to his/her appointment term. The Chairman shall have the following duties:

1. In consultation with the Staff Board Coordinator, delegate the Secretary to prepare agendas for all meetings;
2. Conduct all meetings and hearings of the Board, meaning that the Chairman—
 - i. Is responsible for maintaining order.
 - ii. Should begin the meeting promptly at the scheduled hour if a quorum is present.
 - iii. Should have a well prepared agenda and abide by it.
 - iv. Should be familiar with the procedural rules of the bylaws.
 - v. Keeps the board working together by explaining procedure clearly and communicating the next business in order.
 - vi. Should “assign” the floor by recognizing those members who wish to speak by calling them by name. No other member may interrupt or call out remarks without being out of order. Private discussion between members while another has the floor is out of order and disruptive members should be reminded of this rule.
 - vii. Should impartially call on members wishing to speak and should give members on both sides of an issue an opportunity to speak.
 - viii. Should remain calm and objective, keeping the meeting moving.
 - ix. Should always confirm that all members understand the motion and that the Secretary has fully recorded the motion.
 - x. Should open debate by saying “Is there any discussion?” The Chairman *must* open all debatable questions to debate.
 - xi. Should recognize members who wish to speak by stating their names.
 - xii. Should be a voting member and vote on all cases before the Board. If the Chairman wishes to make a motion, he/she should pass the gavel to the Vice-Chairman for conducting the meeting.
 - xiii. Should request that a motion with grounds (facts and conclusions) be made by any member. If necessary, may assist the member in formulating the motion. (Complex motions may be brought to the meeting pre-written.)
 - xiv. Should request any member to second the motion.

- xv. If a motion fails to get a second, should state, “Since there is no second, the motion is not before the Board.”
 - xvi. If seconded, should ask the members if there is any discussion of the motion.
 - xvii. Should not allow irrelevant discussion.
 - xviii. At the conclusion of any discussion of a seconded motion, should put the question to a vote by requesting the Secretary to call the role.
 - xix. Should announce the result of the vote.
 - xx. At the conclusion, should adjourn the meeting without motion – “If there is no further business and there is no objection, the meeting will be adjourned. There being no objection, the meeting is adjourned.”
3. Act as spokesperson for the Board;
 4. Sign documents for the Board. Note, final decisions are signed by the moving member, the Chairman, and the seconding member;
 5. Act or designate a Board member to act as liaison with other governmental agencies and Town boards;
 6. Assign or delegate tasks to other Board members as may be necessary to perform the Board’s functions;
 7. Transmit reports and recommendations to Town Council;
 8. Ensure that all business is conducted in accordance with the SC Code, the LMO, and these Rules of Procedure;
 9. Cancel a scheduled Board meeting if there are no agenda items; and
 10. Perform other duties approved by the Board.

B. Vice-Chairman. A Vice-Chairman shall be elected by the Board from among the members in the same manner and for the same term as the Chairman. The Vice-Chairman shall serve as Acting Chairman in the absence of the Chairman, and, at such time, the Vice-Chairman shall have the same powers and duties as the Chairman. The Vice-Chairman shall succeed the Chairman, if the office is vacated before the term has expired, to serve the remainder of the unexpired term of the Chairman. A new Vice-Chairman shall be elected at the next regular meeting of the Board. In the absence of both the Chairman and Vice-Chairman, an acting Chairman shall be elected by the members present at a meeting of the Board.

Section 3. Secretary—Appointment and Duties.

During the July meeting of each year, a member of the Town’s Community Development Department shall be appointed by the Board to independently act as the Secretary of the Board. The Secretary will not be eligible to vote or to otherwise participate or deliberate in the proceedings of the Board. The Secretary shall:

1. Publish and post notices of all meetings of the Board;
2. As delegated by the Chairman, prepare meeting agendas;
3. Distribute to each Board member in advance of each meeting--the agenda, prior meeting draft minutes for approval, and all written submissions by staff and applicants on each agenda item, and other relevant materials;

4. Record the proceedings of meetings on audio tape and prepare written minutes of meetings for approval by the Board at its next regular meeting, recording in the written minutes the attendance of members at each meeting, the attendance of Council members, the attendance of staff, and a detailed summary of all discussions during each meeting;
5. Maintain the Board's notices, correspondence, reports and forms as public records for a period of time consistent with the records retention schedule of the Town of Hilton Head Island;
6. Assist in the preparation and forwarding of all reports and recommendations of the Board; and
7. Maintain each final decision of the Board as a permanent record as required by the SC Code.

Section 4. Staff Board Coordinator.

The Community Development Director shall appoint a member of Staff to assist the Chairman and the Secretary in Board coordination, including:

1. Ensuring all postponed agenda items are rescheduled;
2. Ensuring public notices are accurately written for publication;
3. Ensuring the minutes accurately reflect the actions taken in the meeting;
4. Coordinating with pertinent staff on submittal of agenda items to the Secretary for distribution to the Board;
5. Scheduling mandatory training sessions for the Board;
6. Ensuring the Board's Rules of Procedure remain updated;
7. Attending all Board meetings and resolving any questions or requests by the Board; and
8. Assisting the Secretary in the efficient running of the public meetings.

Article V **Meetings and Quorum**

Section 1. Regular and Special Meetings.

- A. Meeting Schedule.** An annual schedule of regular meetings and work sessions of the Board shall be adopted, published and posted at the Town Government Center in late Fall of each year for the next calendar year. Unless rescheduled by a vote of the Board, meetings shall be held at the time and place stated in notices. Meetings shall be open to the public.
- B. Regular Meetings.** Regular Meetings of the Board shall be held on the fourth Monday of each month or such other date as determined by the Chairman or with input from Staff. Notification of all Applications for Appeal, Variance and Special Exception scheduled and any other matters for consideration at each regular meeting of the Board will be in accord with the public notice requirements of the SC Code as implemented by the Town's LMO.
- C. Special Meetings.** Special Meetings of the board may be called at any time by the Chairman or requested by the Staff. At least forty eight (48) hours public notice shall be provided for any Special Meeting of the board including the time, place and particular agenda item(s) scheduled for consideration consistent with the notice requirements of the SC Code as implemented by the Town's LMO.

D. Cancellation of Meetings. Whenever there is no business scheduled for any Regular or Special Meeting of the Board, the Chairman or Staff may cancel such Regular Meeting by giving notice to all members of the Board, as well as the public, no less than twenty-four (24) hours prior, whenever possible, to the time set for any such Regular Meeting.

Section 2. Quorum.

A majority of the Board shall constitute a quorum for the conduct of business. The Secretary will notify the Chairman in the event projected absences will result in the lack of a quorum. If a quorum is established, then a member leaves, the quorum is no longer present. In the absence of a quorum, no further business requiring a vote shall be transacted and any such business shall be postponed to the next meeting.

Section 3. Conflict of Interest

At a minimum, South Carolina law regarding conflicts of interest [S. C. Code Ann. § 8-13-10, *et seq.*, (Supp. 1994)] shall control Board members' actions. In addition, any member of the Board who believes that he or she has or may have a conflict of interest of any nature on any matter before the Board shall, prior to the case at the Regular or Special Meeting at which such matter may be heard or considered by the Board:

1. Prepare a written Potential Conflict of Interest Form describing the matter requiring action or decisions and the nature of his/her potential conflict of interest with respect to the action or decision;
2. File the Potential Conflict of Interest Form with the Secretary; and,
3. Provide a copy of the Potential Conflict of Interest Form to the Chairman.

Upon receipt of a Potential Conflict of Interest Form from any member of the Board, as required in section II (J)(A), *supra.*, the Chairman shall cause the Potential Conflict of Interest form to be recorded in the minutes and shall require that the member filing such Potential Conflict of Interest Form be excused from any votes, deliberations, and any other actions on the matter on which the potential conflict of interest or conflict of interest exists.

Any Board member so disqualified shall leave the dais while the disqualifying matter is being considered and refrain from deliberating or voting on the question.

Article VI
Meeting Administration, Public Comment,
Notices, Fees, Voting Supplemental Submissions/Briefs

Section 1. Media Notices.

The Secretary shall give the notice required by statute or ordinance for all meetings of the Board as per Section 16-2-102.E of the LMO. All Board meetings shall be open to the public and all requirements of the South Carolina Freedom of Information Act [S. C. Code Ann. § 30-4-10, *et seq.* (Supp. 1994)] shall be complied with in the conduct of meetings.

Section 2. Agenda (Order of Business)

A written agenda shall be furnished by the Secretary to each member of the Board and media. An agenda may be changed at the related meeting by a majority vote of the members present. Public Hearing items should be so noted with each pertinent item. Generally, the agenda should contain:

1. Call to Order;
2. Roll Call;
3. Freedom of Information Act Compliance;
4. Use of Cellular Telephones or Other Electronic Sound Emitting Devices Prohibited;
5. Review of Meeting Protocol as described within, including Citizen Participation;
6. Approval of Agenda;
7. Approval of Minutes of Previous Meeting
8. Old Business;
9. New Business;
10. Board Business;
11. Staff Reports;
12. Adjournment.

Section 3. Minutes.

A. Meetings. Minutes of meetings is governed by the Code of South Carolina (30-4-70 through 30-4-90). Minutes of each Board meeting shall be recorded by the Secretary and approved at the next available meeting after their preparation. Final approved Minutes shall be available on microfilm for previous years, and may be posted on the Town's Web site for public information.

B. Minimum Contents of Minutes.

1. Kind of meeting (regular or special).
2. Name of the organization.
3. Date and place of the meeting.
4. Presence of the Chairman and Secretary or the names of substitutes.
5. Presence of a quorum.
6. Names of all Board members, Council members, and Staff.

7. Time the meeting was called to order.
8. Whether the minutes of the previous meeting were approved or corrected.
9. All adopted and defeated motions and grounds (facts and conclusions). Withdrawn motions need not be recorded.
10. Name of the maker of the motion and the seconding member.
11. Summary of all presentations and discussions.
12. Motions, including proposed findings and conclusions, must be recorded verbatim.
13. Record the vote of each member upon each question, or, if absent or failing to vote, indicating that fact.
14. The adjournment and the time of adjournment.

C. Lack of Quorum. If there is lack of a quorum of the Board, minutes may be recorded but shall include a statement in the header of each page indicating that a quorum was not present and the minutes are not official. Such minutes shall not be approved by the Board at a later meeting. (There are different quorums, depending on the agenda item.)

Section 4. Public Comment.

In the case of a Variance or Special Exception application, at the conclusion of presentations by Staff and the Applicant, the Chairman will open the public hearing. The Chairman may set a time limit for all public comments and may determine the order of the comments. The Chairman will recognize citizens to comment and request that they sign up to speak at the podium. Each person will have the opportunity to speak for three (3) minutes. At the conclusion of the public comment, the Chairman will close the public hearing. Staff and/or the Applicant may request that the Chairman allow additional clarification after the public comments. Public comment is not permitted in a case involving an appeal from an Administrator decision.

Section 5. Submission Deadline for Regular Meetings.

The deadline for the filing of a complete Application with narrative for Variance or Special Exception or Request for Appeal shall be thirty (30) calendar days prior to any Regular Meeting of the Board. Any submission or brief containing any citation to an opinion of a court must include a complete copy of the cited opinion.

Section 6. Meeting Protocol.

The Chairman will review the protocol at the start of each meeting. The meeting protocol includes further information about the following: speaker sign-up sheet, length of time for speakers, the order of presentation, and the opening and closing of a public hearing. The speaker sign-up sheet will be placed at the podium for speakers to sign when they come up to speak.

Section 7. Filing of Application, Fees and Notice.

All Applications and Appeals scheduled for review by the Board shall be filed by the interested property owner(s) or by a property owner aggrieved by an Administrator's decision, or by a representative with a written certification of authority by such property owner. All Applications and Appeals shall satisfy all fees and notice requirements in accord with the provisions outlined in the LMO. In any case where the owner of record of the real property affected by any Application for Special Exception or Application for Variance, or his/her certified representative, is not the Applicant, the Applicant shall serve notice of the Application to the contiguous owner(s) of record within the time frames and as described in the LMO. Such notice shall include the time and place of the Board meeting at which the Application shall be heard.

Section 8. Motions and Final Decisions.

A Motion by a Board member is the procedure leading to a final decision by the Board when the Motion is seconded by another Board member and adopted by a vote of a quorum of the Board. A Motion is to be made to describe the proposed decision with findings and conclusions to support the Motion. If the Motion is seconded and adopted by the Board, the final decision, contained in a Notice of Action, must be in writing and be permanently filed in the office of the Board as a public record. The final decision must include findings and conclusions and be delivered to parties of interest by certified mail.

Section 9. Voting.

1. A Board member must be present at the beginning of each case to be permitted to discuss and vote on the case. If a Board member that was absent at the beginning of the hearing establishes requisite knowledge of the case, the member may be permitted to discuss and vote on the case by a majority vote of the Board.
2. All members of the Board, including the Chairman, shall be voting members, and shall be entitled to vote on any issue before the Board unless disqualified by law.
3. For Appeals from Administrator's decision, a majority vote of the entire Board shall be necessary, thus requiring at least 4 affirmative votes to pass a motion.
4. A simple majority of a quorum shall be required to conduct all other Board business including a decision on an Application for Variance or Special Exception.

Section 10. Supplemental Submissions/Briefs.

Any supplemental written submission or legal brief must be delivered [One (1) hard copy or one (1) copy sent via e-mail] to the Secretary of the Board no later than 8:00am four business days before the public meeting day in order for the Secretary to distribute such submission to each Board member by the close of business that day. Town Staff, or the opposing party, has two business days after receipt of the supplemental submission to respond in writing. This excludes any business days when the Town is closed. The Board reserves the right to require or permit later written submissions or briefs and/or proposed findings of fact and conclusions of law to be submitted by the Appellant, Applicant for Variance or Special Exception, or Town Staff. Any

submission or brief containing any citation to an opinion of a court must include a complete copy of the cited opinion. Any written or oral information sent directly to any Board member shall be disregarded and promptly turned over to the Chairman through the Secretary of the Board.

Section 11. Communication Among Board Members or With an Outside Party.

- A. There shall be no communication in writing, orally, or by e-mail by any Board member with any other Board member or any outside party regarding the substance of any matter before the Board that is or may be brought to a vote other than during a public meeting.
- B. Once a decision has been rendered by the BZA, there shall be no further discussions by any Board member with staff, applicants or their attorneys or representatives. Any such communications regarding a decision should be made to the Town Attorney.
- C. Communication with staff or outside parties to communicate procedural matters or general positions or opinions of the BZA will be at the discretion of the Chairman or by an affirmative vote of the majority of the Board members. The Chairman or his designee will be responsible for all such written/verbal communications with anyone other than the remainder of the Board members and Staff.
- D. Board members should refrain from discussing an upcoming agenda item with the Applicant, his Attorney, or his Agent, either through written or verbal communication. Board members should refrain from discussing an upcoming agenda item with Staff either through written or verbal communication, except to clarify facts or request additional information. All discussion of the item should take place in the public meeting. This is to avoid the appearance of improper ex parte communications.

Article VII

Procedures for Hearing an Application for a Variance

The following procedures shall be applicable in the presentation of a Request for a Variance.

Section 1. Presentation of the Town Staff and Applicant.

1. Staff shall have a maximum of twenty (20) minutes to present the facts and applicable legal principles that the Staff believes support the position of Staff with respect to the Application for a Variance. During the presentation by Staff, members of the Board of Zoning Appeals may ask such questions as they deem appropriate. At the discretion of the Chairman, Staff's time may be extended if the Staff is unable to complete the presentation due to questioning from the Board of Zoning Appeals.
2. The Applicant shall have a maximum of twenty (20) minutes to present the facts and applicable legal principles that the Applicant believes supports the Application for a Variance. During the presentation by the Applicant, members of the Board of Zoning Appeals may ask such questions as they deem appropriate. At the discretion of the Chairman, the Applicant's time may be extended if the Applicant is unable to complete the presentation due to questioning from the Board of Zoning Appeals.

3. The Staff shall have a maximum of five (5) minutes to present any desired rebuttal.
4. Following the presentation, the Board of Zoning Appeals may ask such additional questions of the Applicant or Staff as the members deem appropriate.
5. The Board may subpoena witnesses and in the case of contempt may certify such fact to the Circuit Court having jurisdiction over such matters.

Section 2. Public Comment.

1. The Chair will call on interested citizens and request that they come to the podium, state their name for the record and place their name on the sign up sheet. Each person will have the opportunity to speak for three (3) minutes.
2. The Applicant and/or Town Staff shall clarify any information presented by the public before the Board makes a motion.

Section 3. Vote on Application for Variance.

1. Following the presentation by all parties as set forth above, the Board, upon a Motion duly made and seconded, shall vote on the Application for Variance.
2. The Motion shall contain, at a minimum, a finding of those facts which the member making the Motion deems material to the decision and appropriate references to the relevant criteria of the LMO.
3. Pursuant to the provisions of the LMO the Board shall approve the Application for Variance, approve the Application for Variance with conditions or modifications; or, deny the Application for Variance.
4. Following the vote, the Staff shall prepare a written Notice of Action. The written notice of action shall include decision of the Board as well as the findings of fact and conclusions of law adopted by the Board with respect to the Application for Variance.
5. The Notice of Action shall be mailed by certified letter to the Applicant and record owner of the real property affected by the Application for Variance, if different from that of the Applicant.
6. The decision of the board shall be deemed final and applicable upon mailing of the Notice of Action.
7. The certificate of mailing shall be made a part of the board's file on the Application for Variance.

Article VIII
Procedures for Hearing an Application for Special Exception

The following procedures shall be applicable in the presentation of an Application for Special Exception:

Section 1. Presentation of the Town Staff and Applicant.

1. Staff shall have a maximum of twenty (20) minutes to present the facts and applicable legal principles that the Staff believes support the position of Staff with respect to the Application for a Special Exception. During the presentation by Staff, members of the Board of Zoning Appeals may ask such questions as they deem appropriate. At the discretion of the Chairman, Staff's time may be extended if the Staff is unable to complete the presentation due to questioning from the Board of Zoning Appeals.
2. The Applicant shall have a maximum of twenty (20) minutes to present the facts and applicable legal principles that the Applicant believes supports the Application for a Special Exception. During the presentation by the Applicant, members of the Board of Zoning Appeals may ask such questions as they deem appropriate. At the discretion of the Chairman, the Applicant's time may be extended if the Applicant is unable to complete the presentation due to questioning from the Board of Zoning Appeals.
3. The Staff shall have a maximum of five (5) minutes to present any desired rebuttal.
4. Following the presentation, the Board of Zoning Appeals may ask such additional questions of the Applicant or the Staff as the members deem appropriate.
5. The Board may subpoena witnesses and in the case of contempt may certify such fact to the Circuit Court having jurisdiction over such matters.

Section 2. Public Comment.

1. The Chair will call on interested citizens and request that they come to the podium, state their name for the record and place their name on the sign up sheet. Each person will have the opportunity to speak for three (3) minutes.
2. The Applicant and/or Town Staff shall clarify any information presented by the public before the board makes a motion.

Section 3. Vote on Application for Special Exception.

1. Following the presentation by all parties as set forth above, the Board, upon a Motion duly made and seconded, shall vote on the Application for Special Exception.
2. The Motion shall contain, at a minimum, a finding of those facts which the member making the Motion deems material to the decision and appropriate references to the relevant criteria of the LMO.
3. Pursuant to the provisions of the LMO, the Board shall approve the Application for Special Exception, approve the Application for Special Exception with conditions as stated in the LMO or deny the Application for Special Exception.

4. Following the vote, the staff shall prepare a written Notice of Action. The written notice of action shall include the decision of the Board as well as the findings of fact and conclusions of law adopted by the board with respect to the Application for Special Exception.
5. The Notice of Action shall be mailed by certified letter to the Applicant and record owner of the real property affected by the Application for Special Exception, if different from that of the Applicant.
6. The decision of the board shall be deemed final and applicable upon mailing of the Notice of Action.
7. The certificate of mailing shall be made a part of the board's file on the Application for Special Exception.

Article IX **Procedures for Hearing an Appeal**

The following procedures shall be applicable in the presentation of an Appeal from a decision of any Administrator:

Section 1. Jurisdiction.

Once an appeal has been taken from any final decision of Administrator, the jurisdiction of the Administrator, from which the appeal was taken, shall cease.

Section 2. Presentation of the Appellant, Town Staff and Applicant, and Interested Parties.

1. ~~2-~~ The Applicant Appellant shall have a maximum of twenty (20) minutes to present the facts and applicable legal principles that the Applicant Appellant believes supports the Application for an Appeal. During the presentation by the Applicant Appellant, members of the Board of Zoning Appeals may ask such questions as they deem appropriate. At the discretion of the Chairman, the Applicant's Appellant's time may be extended if the Applicant Appellant is unable to complete the presentation due to questioning from the Board of Zoning Appeals.
2. ~~1-~~ Staff shall have a maximum of twenty (20) minutes to present the facts and applicable legal principles that the Staff believes support the position of Staff with respect to the Application for an Appeal. During the presentation by Staff, members of the Board of Zoning Appeals may ask such questions as they deem appropriate. At the discretion of the Chairman, Staff's time may be extended if the Staff is unable to complete the presentation due to questioning from the Board of Zoning Appeals.
3. Where the Appellant is someone other than the Property Owner of the Property that is the subject of the Appeal, the Property Owner or their Agent shall have a maximum of twenty (20) minutes to present the facts and applicable legal principles that the Property Owner believes supports the position of the Property Owner with respect to the Appeal. During the presentation by the Property Owner or their Agent, members of the Board of Zoning Appeals may ask such questions as they deem appropriate. At the discretion of the Chairman, the Property Owner's time may be extended if the Property Owner is unable to complete the presentation due to questioning from the Board of Zoning Appeals.

4. Where the Appellant is someone other than the ~~Building Permit holder~~ Holder of the Permit or Approval of the Property that is the subject of the Appeal, the ~~Building Permit holder~~ Holder of the Permit or Approval or their Agent shall have a maximum of twenty (20) minutes to present the facts and applicable legal principles that the ~~Building Permit holder~~ Holder of the Permit or Approval believes supports the position of the ~~Building Permit holder~~ Holder of the Permit or Approval with respect to the Appeal. During the presentation by the ~~Building Permit holder~~ Holder of the Permit or Approval or their Agent, members of the Board of Zoning Appeals may ask such questions as they deem appropriate. At the discretion of the Chairman, the ~~Building Permit holder~~ Holder of the Permit or Approval's time may be extended if the ~~Building Permit holder~~ Holder of the Permit or Approval is unable to complete the presentation due to questioning from the Board of Zoning Appeals.
5. ~~3. The Staff shall have a maximum of five (5) minutes to present any desired rebuttal. The Chairman may allow a maximum of five (5) minutes each for all parties to present any desired rebuttal.~~
6. ~~4. Following the presentation, the Board of Zoning Appeals may ask such additional questions of the Applicant/Appellant, Property Owner, ~~Building Permit holder~~ Holder of the Permit or Approval or Staff as the members deem appropriate.~~
7. ~~5. The Board may subpoena witnesses and in the case of contempt may certify such fact to the Circuit Court having jurisdiction over such matters.~~
8. ~~6. Public comment is not permitted in a case involving an appeal from an Administrator decision.~~
9. All parties shall be subject to the submittal requirements as set forth in Article 6, Section 10 of the Rules of the Procedure.

Section 3. Vote on the Appeal.

Following the presentation by all parties as set forth above, the Board, upon a Motion duly made and seconded, shall vote on the Appeal.

1. Pursuant to the provisions of Section 16-2-103.T.4.d of the LMO, the Board shall:
 - a) Affirm the action of the Administrator from which the Appeal was taken; or,
 - b) Modify the action of the Administrator from which the Appeal was taken, and to that end, the Board of Zoning Appeals shall have all of the powers of the Administrator from which the Appeal was taken, and may issue a permit, or direct that a permit be issued; or,
 - c) Reverse the action of the Administrator from which the Appeal was taken, and to that end, the Board of Zoning Appeals shall have all of the powers of the Administrator from which the Appeal was taken, and may issue a permit, or direct that a permit be issued; or,
 - d) Remand the action of the Administrator from which the Appeal was taken for such further proceedings as the Board of Zoning Appeals may deem appropriate.
2. The Motion shall contain, at a minimum, a finding of those facts which the member making the Motion deems material to the decision.
3. Following the Vote, the Board shall issue a written Notice of Action. The written notice of action shall include the decision as well as the findings of fact and conclusions of law adopted by the Board.

4. The Notice of Action shall be mailed by certified letter to the Appellant and Record Owner of the real property affected by the Appeal, if different from that of the Appellant.
5. The decision of the Board shall be deemed final and applicable upon mailing of the Notice of Action.
6. The certificate of mailing shall be made a part of the board's file on the Appeal.

Article X **Procedures for a Remand**

Section 1. Remand.

1. A member of the Board may move for a remand at any time, subject to review and determination by the Board. The motion shall specifically set forth factual and/or legal grounds that cause the record to be insufficient.
2. If a remand is granted, the Town and the Applicant shall obtain and present all additional information needed to render the record sufficient as detailed in the motion for the remand.

Article XI **Motions**

Section 1. Motion for a Reconsideration.

1. The Board may reconsider any decision made under Section 16-2-103.E.3.d, 16-2-103.S.3.d or 16-2-103.T.4.d of the Land Management Ordinance.
2. Any party aggrieved by a decision of the Board, if they desire to do so, is required to file any Petition for Reconsideration by delivering the same to the Administrator within ten (10) days from the date of hearing. "Delivered" as referenced in this section, means actual delivery.
3. The Petition for Reconsideration shall be in writing and shall state with particularity the points alleged to have been overlooked or misinterpreted the Board.
4. The Petition for Reconsideration shall be presented to the Board at the next regular scheduled meeting following the filing of the Petition for Reconsideration after compliance with the public notice requirements for a Board Public Meeting per the LMO.
5. Motions:
 - a. A Motion to Grant the Petition for Reconsideration may only be made by a member of the Board who voted on the prevailing side in the original vote.
 - b. The effect of the granting of a Motion for Reconsideration shall be that the Board will review the entire matter as if no previous vote had been taken.
 - c. A Motion to Deny the Petition for Reconsideration may be made by any member of the Board. The effect of a vote denying a Petition for Reconsideration is that the vote shall be considered to be the Board's final action on the matter. A Notice of Action shall be delivered to the Applicant following such vote.

6. Successive Petitions for Reconsideration are prohibited. No matter that has been reconsidered may be reconsidered a second time. The Board may not reconsider a denial of a Petition for Reconsideration.

Section 2. Motion to Dismiss.

Any interested party to a matter pending before the BZA may file a Motion to Dismiss the pending matter. The purpose of a Motion to Dismiss is to seek dismissal of the matter prior to the hearing on the merits of the pending matter.

1. A Motion to Dismiss may assert matters relating to procedure or jurisdiction including:
 - a. Failure to comply with requirements of the LMO,
 - b. Lack of jurisdiction,
 - c. Standing,
 - d. Other matters not relating to the merits of the matter.
2. A Motion to Dismiss shall be in writing, and be filed and served in accordance with Article VI, Section 10, Supplemental Submissions/Briefs.
3. A Motion to Dismiss may be supported by briefs of the law, affidavits or other matters pertinent to the Motion.
4. Any interested party may file briefs and other materials in response to the Motion, in accordance with Article VI, Section 10, Supplemental Submissions/Briefs.
5. The Motion to Dismiss will be normally heard at the same meeting as the related appeal; however, the Chairman or Vice Chairman, in the absence of the Chairman, upon request, in his sole discretion, may permit the motion to be heard at an earlier meeting.

Section 3. Motion for Postponement.

The Town, the Applicant or a Member of the Board may request a postponement of an application at any time, subject to the review and determination of the Board.

The Chairman or Vice Chairman, in the absence of the Chairman, may for good cause grant one postponement request for a period of up to three months from the original hearing date. Any subsequent postponement requests shall be discussed and voted on by the Board

A Motion for Postponement shall be in writing, stating the reasons for the requested postponement, and be filed and served in accordance with Article VI, Section 10, Supplemental Submissions/Briefs.

Section 4. Motion for Withdrawal of Application.

The applicant may request a withdrawal of an application prior to the ruling. A Motion for Withdrawal of the Application shall be in writing, stating the reasons for the requested withdrawal, and be filed and served in accordance with Article VI, Section 10, Supplemental Submissions/Briefs.

The Board shall have the opportunity to discuss the reasons for the application being withdrawn; unless the project has been abandoned. In the absence of the applicant, if the withdrawal is questioned by the Board, the case will be postponed to the next meeting.

Article XII **Miscellaneous**

Section 1. Executive Session.

If a member determines after reviewing the applicable cases that they would benefit from the advice of legal counsel in Executive Session they shall contact the Chairman or his designee. The Chairman will determine if an Executive Session is warranted. If the Chairman decides that the membership would benefit from an Executive Session, they will inform the Board's Secretary of the request. The Chairman's decision can be overridden by a majority vote of the Board taken at a regular or special meeting of the BZA.

Executive Session is a meeting at which the proceedings are secret. A member can be punished under disciplinary procedure if he violates the secrecy of an executive session. Anyone else permitted to be present is honor-bound not to divulge anything that occurred.

Permitted reasons should include:

1. Personnel reasons
2. Contracts
3. Legal advice relating to pending, threatened or potential claim
4. Discussion regarding development of security personnel
5. Investigative proceedings regarding allegations of criminal misconduct
6. Economic development (specific criteria in FOIA)
7. Legal advice relating to procedural, conflict of interest, or general issues unrelated to a specific matter before the Board.

Entering and Adjourning an Executive Session:

1. A motion to close the current meeting and go into executive session is made and passed by a majority vote;
2. Chairman must announce the specific purpose of the executive session;
3. No formal action may be taken in executive session except to:
 - a. Adjourn
 - b. Return to public session

The Board can request attendance by non-members as they deem appropriate.

Section 2. Recess.

A recess shall be declared as deemed appropriate by the Chairman or by majority vote of the members present at the meeting. No discussion of the agenda item shall be conducted by Board members during the recess.

**For the Board of Zoning Appeals
Town of Hilton Head Island, South Carolina**

Date of Approval: DATE, 2019

By: _____
David Fingerhut
Chairman

DRAFT

Attachment for Reference

TYPES OF MOTIONS

Main Motions	A main motion is defined as a proposal that certain action is taken or an opinion be expressed by the group. The words to use are: "I Move."
Secondary Motions	A secondary motion is one which can be made <i>while</i> the main motion is on the floor and <i>before</i> it has been decided. Secondary motions are divided into three classes which relate to their use in parliamentary procedure. Those classes are: <ul style="list-style-type: none"> ○ Subsidiary motions ○ Privileged motions ○ Incidental motions
Subsidiary Motions	Subsidiary motions relate directly to the motion on the floor. They may change the words, send it to a committee, delay it, etc. They are designed to expedite business by disposing of the pending motion other than by adopting or rejecting it. <i>Subsidiary motions are the class of motions most frequently used in meetings.</i> These motions have rank (order of precedence of motions) among themselves. A motion of higher rank can be made while a motion of lower rank is on the floor. The lower rank motion "yields" to the higher rank motion. (Motion to postpone has higher rank than the motion to commit and takes precedence. If motion to postpone is adopted, the main motion and the motion to commit are postponed until the next meeting.)
Privileged Motions	Privileged motions are motions of an emergency nature, such as to recess or adjourn. They do not relate to the motion on the floor but to the welfare of the group. They are of high rank and must be handled before any other business that may be pending.
Incidental Motion	Incidental motions are procedural. They deal with process, such as enforcing proper procedure, correcting errors, verifying votes, etc. When introduced, they must be decided before business can resume.
Amending Motion	General consent can be used with amendments to motions if the Chairman feels the group will accept the amendment. "If there is no objection, the motion is so amended." <i>Restate the motion.</i>
Motions Commit	Have precedence over the motion to amend. More than one motion can be on the floor but only one question. All pending motions must relate to the main motion on the floor. No new business may be introduced.
Point of Order	Motion used if a board member feels the Chairman is failing to operate within the rules.

Restorative Motions or Motions that Bring Back a Question

Restorative Motion	<p>Allows a group to change its mind.</p> <ul style="list-style-type: none"> ○ They are a separate category because of their contradiction to the parliamentary rule that once a question has been decided it cannot be brought up again at the same meeting. ○ Within limits, members have the right to rethink a situation if they feel their decision has been made too quickly or without enough information. ○ The two most commonly used restorative motions are: <i>Rescind</i> and <i>Reconsider</i>.
Rescind	<p>Rescind is the motion to use to quash or nullify a previously adopted motion. It may strike out an entire motion, resolution, bylaw, etc.</p> <ul style="list-style-type: none"> ○ Rescind is <i>not in order</i> when any action has already been taken as a result of the vote, such as any kind of contract when the other party has been notified. ○ It must be seconded. ○ It requires a <i>two-thirds</i> vote unless <i>notice has been given</i> at the previous meeting, either verbally or in writing. If notice has been given, the motion requires only a <i>majority</i> vote.
Reconsider	<p>Reconsider is the motion which allows a group to reconsider the vote on a motion. It enables a majority of the members, within a limited time, to bring back a motion for further consideration after it has been acted upon. Its purpose is to prevent hasty or ill-advised action.</p> <ul style="list-style-type: none"> ○ Reconsider has special rules to prevent its abuse by a disgruntled minority, since it allows a question already decided to be brought up again. ○ Rules limit who can make the motion. It can only be made by someone who voted on the prevailing (winning) side. ○ It has a <i>time limit</i>. It must be made on the <i>same day</i> that the vote to be reconsidered was taken. ○ It requires a second. ○ It may be debated and it opens up the motion to which it is applied to debate. ○ It requires only a majority vote. ○ It may be made and seconded while other business is pending because of its time limit. However, it is not debated and voted on until the business on the floor is completed. ○ All action that might come out of the original motion is stopped at the time that reconsider is made and seconded. This is the main value of the motion, and it should be made as quickly as the situation calling for it is recognized.
Amend a Motion	<p>Change the wording to make it clearer, more complete, or more acceptable before the motion is voted upon. The amendment must be germane to the motion on the floor to be in order. Adoption of the amendment does not adopt the motion. If the group votes “no” on the amendment, the motion is on the floor in its original wording.</p>
Amend an Amendment	<p>First amendment is called the primary and the amendment to the amendment is the secondary amendment. Only two amendments may be pending at any time. First vote on the amendment to the amendment (secondary), then vote on the</p>

	original amendment (primary), then vote on the main motion. Amendments require a majority vote.
Friendly Amendments	Change in wording to enhance the original motion – can be changed by general consent.
Hostile Amendments	Gives a different meaning to a motion and may defeat the intent of the main motion.
To Commit or Refer a Motion	Sends the question to a small group (committee) to be studied and put into proper form for the group to consider. Motion includes specific directions as to where the question ought to go (what committee). Motion can be applied to any main motion with any amendments that may be pending. It must be seconded, it can be debated, and requires a majority vote.
Postpone	Delays action on a question until later in the same meeting or until the next meeting. <i>A motion cannot be postponed further than the next regular meeting.</i> Can be applied to all main motions, it must be seconded, it can be debated, it can be amended (as to time of the postponement), it requires a majority vote. Motion is called up automatically when the time to which it was postponed arrives (place under Unfinished Business on agenda of next meeting).
Limit Debate	Motion to exercise special control over debate – reducing the number and length of speeches allowed. Used with any motion, must be seconded, is not debatable, can be amended (but only as to the length of speeches or when the vote will be taken), requires 2/3 vote, vote must be taken by show of hands or a rising vote in a large group. (Need a timekeeper and timer if speeches have a time limit.)
Previous Question	The motion used to cut off debate and to bring the group to an immediate vote on the pending motion. (Call the question for an immediate vote). Previous question can be ruled out of order if the motion is debatable and has not received debate. Motion requires 2/3 vote (by show of hands or standing vote). Not debatable.
Postpone Indefinitely	Lowest-ranked subsidiary motion is used to kill a main motion. It avoids a direct vote on the question on the floor. Shouldn't be used.
Lay on the Table	Highest-ranked subsidiary motion. Cannot be amended or debated. It is out of order when used to “kill or avoid dealing with a measure”. Was designed as a courtesy motion to allow a group to set aside a question for something more important, such as arrival of a speaker.
Withdraw a Motion	Permission to withdraw a motion allows a member who realizes he has made a hasty or ill-advised motion to withdraw it with the consent of the group. This device saves time in disposing of the motion. The presiding officer usually handles the request by use of general consent.
Dilatory Tactics	A dilatory tactic is the misuse of parliamentary procedure to deliberately delay or prevent action in a meeting. It is the duty of the presiding officer to prevent a dissident minority from misusing legitimate forms of motions to obstruct business. Such motions should be ruled out of order or those members engaged in such game playing should not be recognized.

TYPES OF VOTES

Majority Vote	<ul style="list-style-type: none"> • More than half of the votes cast. • The minority has the right to be heard, but once a decision has been reached by a majority of the members present and voting, the minority must then respect and abide by the decision.
Silence is Consent	Those members who do not vote, agree to go along with the decision of the majority by their silence.
Two-thirds Vote	A two-thirds vote is necessary whenever you are limiting or taking away the rights of members or whenever you are changing something that has already been decided. A two-thirds vote has at least twice as many votes on the winning side as on the losing side. A show of hands should be taken for <i>all</i> motions requiring a <i>two-thirds</i> vote. If a motion requires a two-thirds vote, the Chairman should inform the group of that.
General Consent	<p>Is an informal agreement of the group, the method in which action is taken without a formal vote or on occasion without a motion. The Chairman initiates the procedure to expedite business. Usually done to approve and correct the minutes.</p> <ul style="list-style-type: none"> • The presiding officer always pauses after asking if there is any objection. If there is <i>any</i> objection, the matter is put to a vote in the usual way. • A member may object because he feels it is important to have a formal vote and dispel any suspicion of railroading.
Tie Vote	Is a <i>lost</i> vote because a majority was not obtained. The <i>Chairman is not compelled to break a tie</i> . While the Chairman has a right to vote as a member, it is recommended he not vote unless the vote is by ballot. He may also vote in cases where the vote would change the result. The Chairman should appear impartial.



TOWN OF HILTON HEAD ISLAND

Community Development Department

TO: Board of Zoning Appeals
FROM: Taylor Ladd, *Senior Planner*
DATE: May 9, 2019
SUBJECT: Substitutions of Nonconformities for Redevelopment

The BZA requested that staff keep them informed of substitutions of nonconformities for redevelopment that are granted by staff. A memo is distributed every month at the regular BZA meetings and is discussed under staff reports on the agenda.

The following language is contained in Section 16-7-101.F, Substitutions of Nonconformities for Redevelopment, which gives the Administrator the power to grant such substitutions for existing nonconforming structures and site features.

LMO Section 16-7-101.F:

“To provide flexibility and encourage redevelopment of sites with nonconforming features or structures, the Official is authorized to approve a Development Plan for such sites if the proposed development:

1. Will not include any new development that increases the amount of encroachment into any required buffer or setback;
2. Will not increase the impervious cover on the site over the maximum allowed for the district or the existing impervious cover, whichever is greater;
3. Will not result in a density in excess of what is allowed under this Ordinance, or the existing density, whichever is greater;
4. Will lessen the extent of existing nonconforming site features to the greatest extent possible;
5. Will not have an adverse impact on the public health, safety or welfare; and
6. Will lessen the extent of nonconformities related to any existing nonconforming structure on the site to the greatest extent possible.”

There have been no Substitutions of Nonconformity for Redevelopment that have been granted by staff since the March 25, 2019 BZA meeting.